

**brother**<sup>®</sup>

Please read this manual thoroughly before using the machine.

**Brother Laser Printer / Scanner / Copier**

**MFC/HL-P2000**

**User's Guide**

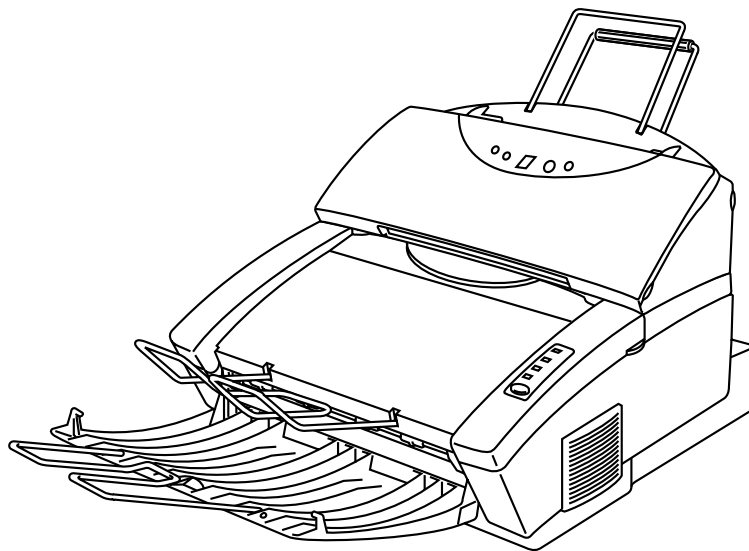

Keep this manual in a convenient place for quick and easy reference at all times.

# TABLE OF CONTENTS

---

## CHAPTER 1 INTRODUCTION

ABOUT THE GUIDEBOOKS	1-1
Finding Out How to Use the Machine	1-1
ABOUT YOUR MACHINE	1-2
Machine Overview	1-2
System Requirements in Brother Printing Solution for Windows®	1-3
Features	1-3
OPERATING AND STORAGE ENVIRONMENT	1-6
Power Supply	1-6
Environment	1-6

## CHAPTER 2 PAPER HANDLING

PAPER SPECIFICATIONS	2-1
DOCUMENT SPECIFICATIONS	2-5
MULTI-PURPOSE SHEET FEEDER FOR PRINTING	2-6
Loading Paper into the Feeder	2-7
Two Side Printing (Manual Duplexing)	2-9
OUTPUT TRAY AND PAPER SUPPORT WIRE	2-10

## CHAPTER 3 PRINT

LAMPS AND SWITCH	3-1
Ready (Paper) Lamp	3-1
Data (Toner) Lamp	3-2
Drum Lamp	3-2
Alarm Lamp	3-2
Switch	3-3
Other Control Features	3-3

## **CHAPTER 4 COPY**

COPYING IN STANDARD MODE	4-1
TO MAKE SETTINGS FOR EACH COPY	<b>4-1</b>
Photo/Text	4-2
Enlarge/Reduce	4-2
The Number of Copies	4-3
Error	4-4

## **CHAPTER 5 SCAN**

SCANNING FROM TWAIN COMPLIANT APPLICATIONS	5-1
SCANNING FROM THE VISIONEER PaperPort® LE SOFTWARE	5-2
SCANNING FROM THE UNIMESSAGE™ VIEWER SOFTWARE	5-3

## **CHAPTER 6 MAINTENANCE**

REPLACING THE TONER CARTRIDGE	6-1
REPLACING THE DRUM UNIT	<b>6-7</b>
CLEANING THE MACHINE	6-11
Cleaning the Machine Exterior	6-11
Cleaning the Machine Interior and Drum Unit	6-12
Cleaning the Scanning Unit	6-15
RE-PACKING THE MACHINE	6-16

## CHAPTER 7 TROUBLESHOOTING

ALARM INDICATIONS AT A GLANCE	7-1
Operator Calls for the Printing Function	7-1
Operator Calls for the Copying and Scanning Function	7-3
Service Calls for the Printing Function	7-4
Service Calls for the Copying and Scanning Function	7-5
PAPER JAMS	7-6
Q & A	7-10
Setting Up the Machine Hardware	7-10
Setting Up the Machine for Windows	7-10
Setting Up the Machine for DOS	7-11
Paper Handling	7-12
Printing	7-13
Copy	7-14
Scan	7-14
Print Quality	7-15

## APPENDIX

PRINTER SPECIFICATIONS	A-1
Printing	A-1
Copying	A-2
Scanning	A-2
Functions	A-3
Electrical and Mechanical	A-3
PARALLEL INTERFACE SPECIFICATIONS	A-4
RESIDENT FONTS	A-6
Bitmapped Fonts	A-6
SYMBOL SETS/CHARACTER SETS	A-7
HP LaserJet IIP Mode	A-7
EPSON Mode	A-7
IBM Mode	A-7
REGULATIONS	A-12

## INDEX

## Definitions of Warnings, Cautions, and Notes

The following conventions are used in this User's Guide:

### **Warning**

Indicates warnings that must be observed to prevent possible personal injury.

### **Caution**

Indicates cautions that must be observed to use the machine properly or prevent damage to the machine.

### **Note**

Indicates notes and useful tips to remember when using the machine.

## To Use the Machine Safely

### **Warning**

After you have just used the machine, some internal parts of the machine are extremely hot. When you open the top cover, never touch the shaded parts shown in the following illustration.

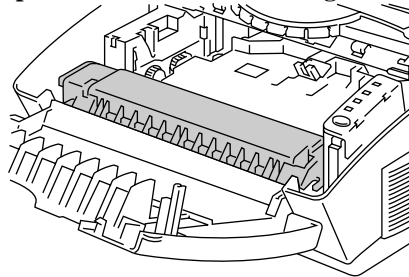

 **High Temperature**  
Inside the Machine

### **Warning**

There are high voltage electrodes inside the machine. Before cleaning the machine, make sure to turn off the power switch and unplug the power cord from the power outlet.

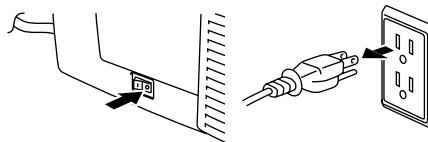

Turning off the Switch and Unplugging the Machine

## Shipment of the Machine

If for any reason you must ship your Machine, carefully package the Machine to avoid any damage during transit. It is recommended that you save and use the original packaging. The Machine should also be adequately insured with the carrier.

### Warning

When shipping the Machine, the DRUM UNIT assembly including the TONER CARTRIDGE must be removed from the Machine and placed in the plastic bag. **Failure to remove and place it in the plastic bag during shipping will cause severe damage to the Machine and will VOID THE WARRANTY.**

1 Remove the drum unit.

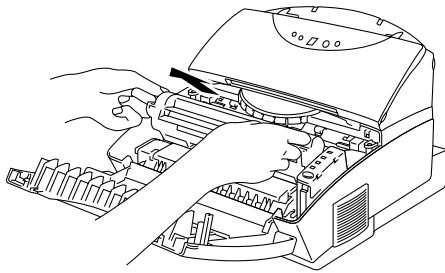

2 Place it in the plastic bag and seal the bag completely.

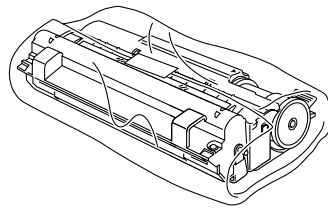

3 Remove the AC cord, the extension wire of the paper tray and the document support from the machine. Re-pack the machine. See **“REPACKING THE MACHINE”** in Chapter 6.

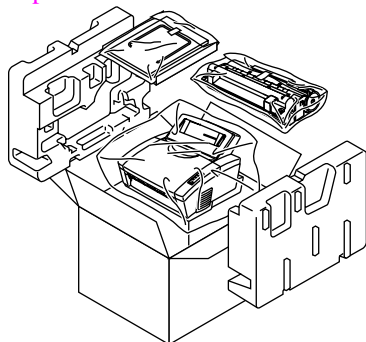

**(For USA & CANADA Only)**

For technical and operational assistance, please call:

In USA	1-877-284-3238	(outside California)
	949-859-9700 Ext. 329	(within California)
In CANADA	1-800-853-6660	
	514-685-6464	(within Montreal)

If you have comments or suggestions, please write us at:

In USA	Printer Customer Support Brother International Corporation 15 Musick Irvine, CA 92718
In CANADA	Brother International Corporation (Canada), Ltd. - Marketing Dept. 1, rue Hôtel de Ville Dollard-des-Ormeaux, PQ, Canada H9B 3H6

**BBS**

For downloading drivers from our Bulletin Board Service, call:

In USA	1-888-298-3616
In CANADA	1-514-685-2040

Please log on to our BBS with your first name, last name and a four digit number for your password. Our BBS supports modem speeds up to 14,400, 8 bits no parity, 1 stop bit.

**Fax-Back System**

Brother Customer Service has installed an easy to use Fax-Back System so you can get instant answers to common technical questions and product information for all Brother products. This is available 24 hours a day, 7 days a week. You can use the system to send the information to any fax machine, not just the one you are calling from.

Please call 1-800-521-2846 (USA) or 1-800-681-9838 (Canada) and follow the voice prompts to receive faxed instructions on how to use the system and your index of Fax-Back subjects.

**DEALERS/SERVICE CENTERS (USA only)**

For the name of an authorized dealer or service center, call 1-800-284-4357.

**SERVICE CENTERS (Canada only)**

For service center addresses in Canada, call 1-800-853-6660

**INTERNET ADDRESS**

For technical questions and downloading drivers: <http://www.brother.com>

# CHAPTER 1 INTRODUCTION

## ABOUT THE GUIDEBOOKS

---

### Finding Out How to Use the Machine

You have two guidebooks for this machine. Read each guidebook in the following order:

1. Read the Quick Setup Guide to set up your machine and to ensure proper connection with your computer. It also contains information for installing the printer driver, fonts and Remote Printer Console Program.

2. Read this On-line User's Guide to get information about the following.

- Features and operating environment requirements of your machine – Chapter 1
- Paper Handling – Chapter 2
- Print – Chapter 3
- Copy – Chapter 4
- Scan – Chapter 5
- Maintenance – Chapter 6
- Troubleshooting – Chapter 7
- Specifications – Appendix
- Index



## ABOUT YOUR MACHINE

---

### Machine Overview

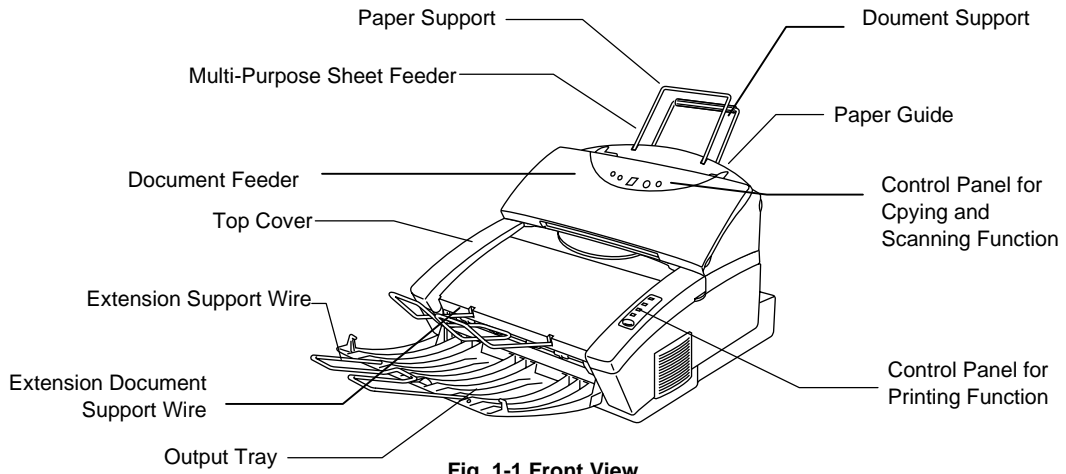

Fig. 1-1 Front View

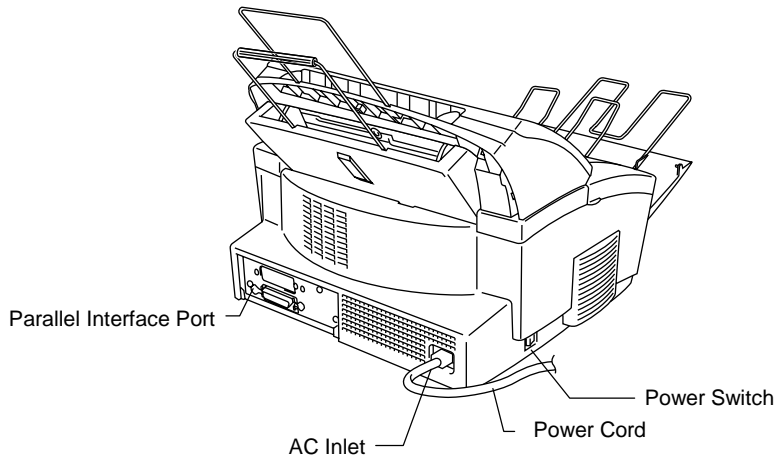

Fig. 1-2 Rear View

## System Requirements in Brother Printing Solution for Windows®

Check the following system requirements to setup and operate the machine in Brother Printing Solution for Windows:

- IBM PC or compatible with 80486 SX or higher microprocessor
- Parallel interface (or printer port)
- 8 MB or more of memory (for Windows® 3.1/3.11)  
16 MB or more of memory (for Windows® 95/98/NT)
- 10 MB of space available on your hard disk for the printer driver and all fonts
- 20 MB of space available on your hard disk for Visioneer PaperPort® LE Software
- Microsoft Windows® 95/98, 3.1/3.11 or Windows® NT 4.0

## Features

This machine has the following features:

- ❑ **High Resolution and Fast Printing Speed**  
True 600 dots per inch (dpi) with microfine toner and up to 10 pages per minute (ppm) printing speed (A4 or Letter paper).
- ❑ **Versatile Paper Handling**  
The machine has a multi-purpose sheet feeder and straight paper path mechanism. Using this mechanism, you can load A4, letter, legal, B5, A5, A6 and executive sizes of paper, and various types of paper including envelopes, organizer paper and your custom paper size. The multi-purpose sheet feeder also allows manual paper loading, so you can also use labels and transparencies.
- ❑ **Copier**  
You can easily copy at a comfortable speed with only one push of a button. You can also enlarge or reduce the copying size.
- ❑ **Document Management Application ‘Visioneer PaperPort® LE Software’ (MFC-P2000)**  
Visioneer PaperPort® LE Software is a document management application which contains a viewer, editor and filing system and various links to other applications. Visioneer PaperPort® LE Software is a sophisticated application and has widespread industry acceptance and endorsements.
- ❑ **A Sophisticated Viewer Software ‘WordCraft Unimessage™ Viewer Software’ (HL-P2000)**  
WordCraft Unimessage™ Viewer is a sophisticated viewer for displaying and editing graphic files. In addition to the usual image editing functions (object drawing, annotations, highlighting, etc.) you will also be able to use this software to view both colour and monochrome images, create cover sheets for use with HL-P2000, display thumbnails of graphics files in any of your directories and set up a referencing system for your files using DIR (Document Indexing Retrieval).

❑ **TWAIN Compliant Scanner Driver**

The scanner driver is TWAIN compliant which is a defacto standard. You can use the scanner from other TWAIN compliant applications as well as the PaperPort application or Unimessage™ viewer application.

❑ **Enhanced Printing Performance and User-Friendly Operation for Windows®**

The dedicated printer driver and TrueType™-compatible fonts for Microsoft® Windows 95/98 and Windows 3.1 are available on the floppy disk and CD-ROM supplied with your machine. You can easily install them into your Windows system using our installer program. The driver supports our unique compression mode to enhance printing speed in Windows applications and allows you to choose various machine settings including toner saving mode, custom paper size, sleep mode, gray scale adjustment, resolution and so forth. You can easily set these print options through the Machine Setup Menu within the Windows Control Panel.

❑ **Remote Printer Console Program for DOS**

The utility program, Remote Printer Console (RPC), is available on a floppy disk supplied with your machine. When you operate your computer in the DOS (Disk Operating System) environment, this program allows you to easily change the default settings of the machine such as fonts, page setup, emulations and so on.

This program also provides a status monitor program, which is a Terminate-and-Stay Resident (TSR) program. It can monitor the machine status while running in the background and report the current status or errors on your computer screen.

❑ **Popular Printer Emulation Support**

This machine supports the following popular printer emulation modes: HP LaserJet IIP, Epson FX-850 and IBM Proprinter XL. When you use DOS application software or Windows version 3.0 or earlier, you can use any of these emulations to operate the machine. The machine also supports auto-emulation switching between HP and Epson or HP and IBM. If you want to select the printer emulation, you can do it using the Remote Printer Console Program.

❑ **Machine Status Monitor with Bi-directional Parallel Interface**

The printer driver can monitor your machine's status using bi-directional parallel communications. A high quality bi-directional parallel printer cable is recommended.

The machine status monitor program can show the current status of your machine. When printing, the animated dialog box appears on your computer screen to show the current printing process. If an error occurs, a dialog box will appear to let you know what to correct. For example: when your machine is out of paper, the dialog box will display "No Paper" and instructions for the proper corrective action.

❑ **Enhanced Memory Management**

The machine provides its own data compression technology in the machine hardware and the supplied printer driver software, which can automatically compress graphic data and font data efficiently into the machine's memory. You can avoid memory errors and print most full page 600 dpi graphic and text data, including larger fonts, with the machine's standard memory.

❑ **Environment-Friendly Economy Printing Mode**

This feature will cut your printing cost by saving toner. It is useful to obtain draft copies for proof-reading. You can select from two economy modes—25% toner saving and 50% toner saving—through the Windows printer driver supplied with your machine.

**Sleep Mode (Power Save Mode)**

When the machine is not used for a certain amount of time, sleep mode automatically reduces power consumption. The machine consumes less than 13 W when in sleep mode.

**Low Running Cost**

Since the toner cartridge is separate from the drum unit, you need to replace only the toner cartridge after approximately 2,400 pages, which is cost effective and ecologically friendly. **(Some models are supplied with a starter toner cartridge which must be replaced after 1,000 pages.)**

The actual number of pages printed with each toner cartridge may vary depending on your average type of print job.

## **OPERATING AND STORAGE ENVIRONMENT**

---

Please take note of the following before using the machine.

### **Power Supply**

Use the machine within the specified power range.

AC power:  $\pm 10\%$  of the rated power voltage in your country

Frequency: 50/60 Hz (220 V– 240 V) or 50/60 Hz (110–120 V)

The power cord, including extensions, should not exceed 5 meters (16.5 feet).

Do not share the same power circuit with other high-power appliances, particularly an air conditioner, copier, shredder and so on. If it is unavoidable that you must use the machine with these appliances, it is recommended that you use an isolation transformer or a high-frequency noise filter.

Use a voltage regulator if the power source is not stable.

### **Environment**

The machine should be installed near a power outlet which is easily accessible.

Use the machine only within the following ranges of temperature and humidity.

Ambient temperature: 10°C to 32.5°C (50°F to 90.5°F)

Ambient humidity: 20% to 80% (without condensation)

The machine should be used in a well ventilation room.

Place the machine on a flat, horizontal surface.

Keep the machine clean. Do not place the machine in a dusty place.

Do not place the machine where the ventilation hole of the machine can be blocked.

Do not place the machine where it is exposed to direct sunlight. Use a blind or a heavy curtain to protect the machine from direct sunlight when the machine is unavoidably set up near a window.

Do not place the machine near devices that contain magnets or generate magnetic fields.

Do not subject the machine to strong physical shocks or vibrations.

Do not expose the machine to open flames or salty or corrosive gasses.

Do not place objects on top of the machine.

Do not place the machine near an air conditioner.

Keep the machine horizontal when carrying it.

Do not cover the slots in the top cover.

## CHAPTER 2 PAPER HANDLING

### PAPER SPECIFICATIONS

The machine can handle paper that has the following specifications.

Paper Type	Paper Size
Cut sheet	A4, Letter, Legal, B5(JIS/ISO), A5, A6, Executive, Custom size (70-216 x 127-356 mm, 2.75-8.5 x 5-14 inches)
Envelopes	DL, C5, COM-10, Monarch, 9" x 12"
Organizer	Day-Timer® J, K, L (70-216 x 127-356 mm, 2.75-8.5 x 5-11 inches)
Labels and Transparencies	A4, Letter (70-216 x 127-356 mm, 2.75-8.5 x 5-14 inches)

#### Paper Capacity in Feeder

Multi-purpose Sheet Feeder:

**A4/Letter paper:** Up to 22 mm (0.87 inch) in height (up to the mark)  
Approx. 200 sheets of 75 g/m<sup>2</sup> (20 lb.)  
30 sheets of 158 g/m<sup>2</sup> (42 lb.) A4/Letter paper

**Legal paper:** 100 sheets

**Envelopes, Organizer:** 10 sheets

**Output Tray:** Approx. 100 sheets of 75 g/m<sup>2</sup> (20 lb.) A4/Letter paper

	Cut Sheet	Envelope
Basis Weight	60 to 158 g/m <sup>2</sup> (16 to 42 lb.)	75 to 90 g/m <sup>2</sup> (20 to 24 lb.) single thickness
Caliper	±0.03 to ±0.08 in. (0.08 to 0.2 mm)	0.0033 to 0.0058 in. (0.084 to 0.14 mm) single thickness
Moisture Content	4% to 6% by weight	4% to 6% by weight
Smoothness	100 to 250 (Sheffield)	100 to 250 (Sheffield)

#### Recommended paper

**Cut sheet:** Xerox 4200  
(in USA) / Xerox 80 Premier Paper (in Europe)  
or equivalent

**Label:** Avery laser label or equivalent

**Transparency:** 3M CG3300 or equivalent

### **Remarks**

It is recommended that you test paper, especially special sizes and types of paper and heavy paper, on this machine before purchasing large quantities.

Avoid using coated paper, such as vinyl coated paper.

Avoid using preprinted or highly textured paper.

Use a recommended type of paper, especially plain paper and transparencies, for optimum printing. For more information on paper specifications, consult your nearest authorized sales representative or the place you purchased your machine.

If the paper has problems feeding from the multi-purpose sheet feeder, use the manual feed slot and try again.

Use neutral paper. Do not use acid paper to avoid any damage to the machine drum unit.

You can use recycled paper in this machine.

Make sure you select the appropriate media type in the printer driver for optimum printing.

The print quality might be degraded or the life of drum unit might be shortened with the following usage.

- Using paper with narrower width than A4/Letter continuously
- Printing only a certain range of paper widths continuously
- Using the machine for a special job (i.e. printing of name cards etc.)

### **Cut Sheet**

We recommend you use long-grained paper for the best print quality.

If you are using short-grained paper, it could be the cause of paper jams.

### **Labels / Transparencies**

Avoid feeding labels with carrier sheets exposed, or your machine will be damaged.

We recommend you use label or transparencies which are designed for use in laser printers.



### Special Paper

Before using paper with holes such as organizer sheets, you must fan the stack well to avoid paper jams and misfeeds.

Do not use organizer sheets that are stuck together. The paste used might cause damage to the machine.

Before using any paper, make sure that it is not curled. If it is, you should straighten the paper as much as possible. Feeding curled paper can cause paper jams and misfeeds.

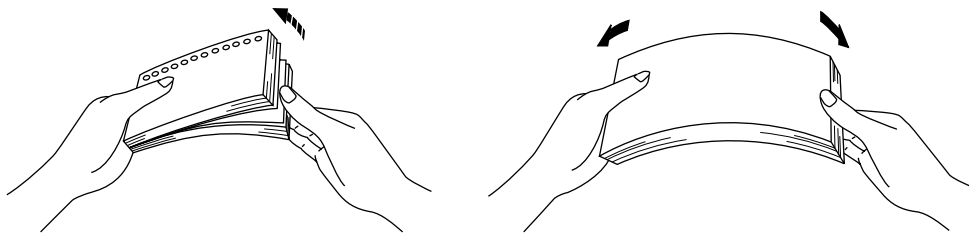

**Fig. 2-1 Fan the Paper and Straighten the Paper**

The machine can handle 9" width paper. However, you may get stains on the paper outside 8.5" width or on the back of the paper.

If different types of paper are loaded at the same time in the feeder, it may cause paper jams or mis-feeds.

## Envelopes

The following types of envelopes are not recommended for use.

- Damaged, curled, wrinkled, or irregularly shaped envelopes
- Extremely shiny or highly textured envelopes
- Envelopes with clasps
- Envelopes with self-adhesive closures
- Envelopes of baggy construction
- Envelopes not sharply creased
- Embossed envelopes
- Envelopes already printed by a laser printer
- Envelopes pre-printed on the inside
- Envelopes that cannot be arranged uniformly when placed in a pile

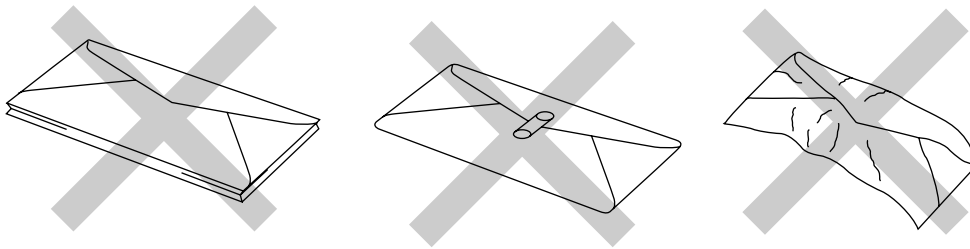

**Fig. 2-2 Envelopes**

**Printable Area** The figure below shows the physically printable area.  
(Except 9"x12" envelope)

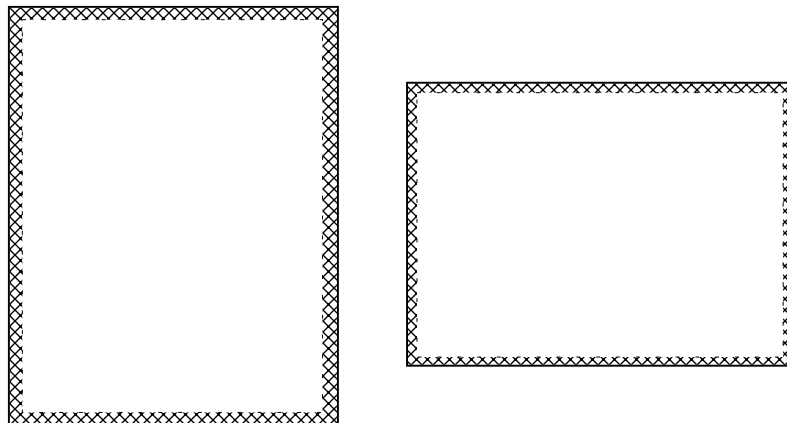

 Unprintable area  
Approximately 4 mm(0.16 inch) for any sizes of paper

**Fig. 2-3 Printable Area**

## DOCUMENT SPECIFICATIONS

The machine can handle documents that have the following specifications.

Document Size	70-216mm wide, 100-360mm long
Document Basis Weight	52 to 90 g/m <sup>2</sup> (13.9 to 24 lb.)
Document Thickness	0.06mm to 0.12mm

### Paper Capacity in Document Feeder

**A4/Letter paper:** Approx. 10 sheets of 75 g/m<sup>2</sup> (20 lb.)

**Envelopes, Organizer:** 10 sheets

#### ⚠ Caution

- Do not load labels in the document feeder.
- Do not load transparencies in the document feeder.

#### ✍ Note

- When loading multiple documents in the document feeder, load the same size and type of document.
- When loading multiple documents in the document feeder, fan the documents before loading.
- Documents printed in color might stain the scanning unit. If this happens, clean the scanning unit.

**Scannable Area** The figure below shows the physically scannable area. The scannable area of your machine begins at approximately 3mm (0.12") from the edge of the document.

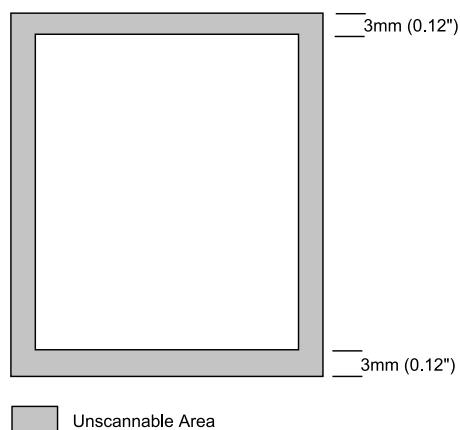

**Fig. 2-4 Scannable Area**

## **MULTI-PURPOSE SHEET FEEDER FOR PRINTING**

---

The machine has a multi-purpose sheet feeder that can feed plain paper, envelopes, transparencies and organizer paper.

To use the multi-purpose sheet feeder, follow these steps:

1. Make sure that you have selected the proper paper source, paper size, media type and orientation.

**Note**

- You may select the proper paper source, paper size and orientation in your application software.
- If your application software does not support your custom paper size, select the next paper size up that is closest but larger than the custom size. Then adjust the print area by changing the right and left margins in your application software.

2. Make sure that the multi-purpose sheet feeder contains the selected size of paper in the selected orientation. If necessary, change the paper in the feeder.
3. Send your file or document to the machine.

When the machine receives data, it begins the print process by loading paper from the multi-purpose sheet feeder. If the machine is in sleep mode when it receives data, it will wake up and start the printing process automatically.

## Loading Paper into the Feeder

To load paper into the feeder, follow these steps.

1. Open the multi-purpose sheet feeder by gently pulling the lid forward towards you. (①).
2. Load paper into the multi-purpose sheet feeder with the printing surface face down. (②)

### ⚠ Caution

- The feeder can hold up to 200 sheets of plain paper (75 g/m<sup>2</sup>, 20 lb.). If you load too many sheets, paper jams could occur.
- Make sure that the paper is stacked below the ▼ mark.
- If there is still some paper in the feeder, you must first remove it, put it together with the new paper and then insert the stack in the feeder.

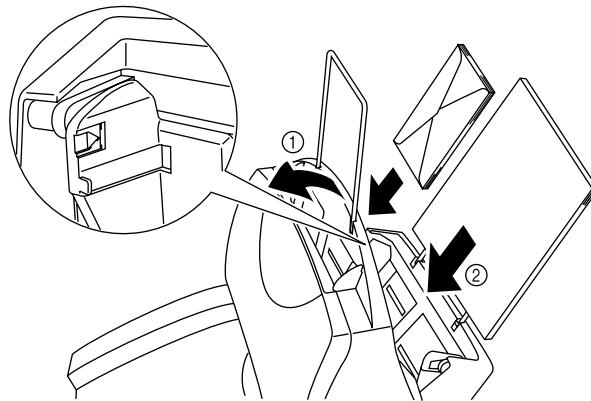

**Fig. 2-5 Opening the Feeder and Loading Paper or Envelopes in the Feeder**

### ✍ Note

If you load envelopes in the feeder, make sure they are inserted in the direction shown above.

3. Move the paper guide to the paper width. ( ① )

**⚠ Caution**

Failure to set the paper guide to the paper size may cause paper skew or jams.

4. Close the multi-purpose sheet feeder. ( ② )

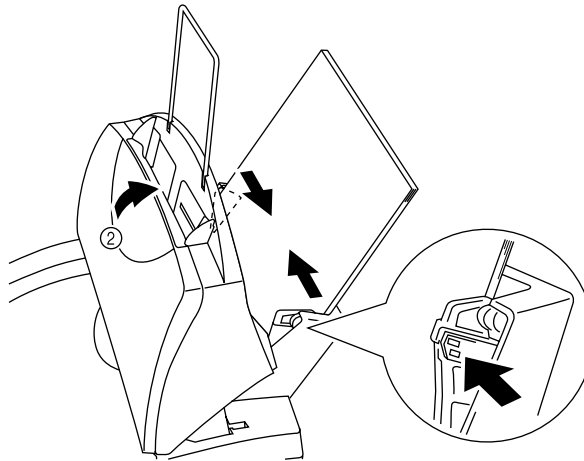

**Fig. 2-6 Moving the Paper Guide and Closing the Feeder**

**🔧 Note**

If the multi-purpose sheet feeder runs out of paper when you try to print, the **Alarm** and **Paper** lamps blink to alert you to a paper empty error. You have to load paper in the feeder and push the panel switch to cancel the alarm and continue printing. If paper jams in the machine, the **Alarm** and **Paper** lamps also blink. If the error is a paper jam, clear it referring to **"PAPER JAMS"** in Chapter 7.

## Two Side Printing (Manual Duplexing)

The supplied printer driver for Windows 95,98 or Windows 3.1 enables manual duplex printing. For more information about settings, see the help text in the printer driver.

The machine prints all the even numbered pages on one side of the paper first, and then prints all the odd pages on the reverse side of the paper.

When you have finished printing the even numbered sides of the paper, the driver instructs you to re-insert the paper by a pop-up message on the computer screen. Follow the instructions on how to reinsert the paper.

### Note

- Before re-inserting the sheets, you have to straighten them, or you will get paper errors.
- The use of very thin or very thick paper is not recommended.
- If you encounter a double feeding error, we recommend that you hold all sheets of paper except the front sheet while the paper is feeding.

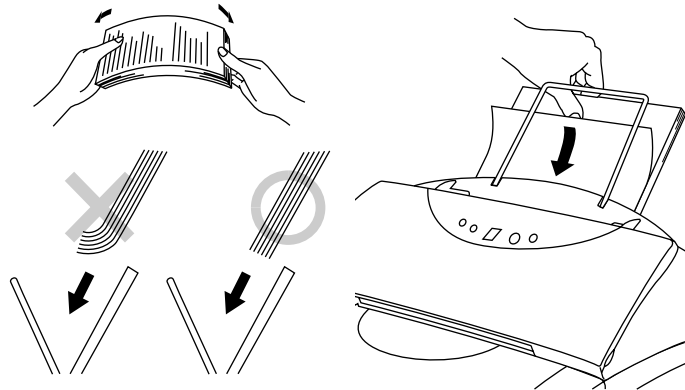

Fig. 2-7 Notes for Manual Duplexing

### Note

When you use the Manual Duplex function, it is possible that paper jams may occur or print quality might not be satisfactory.

## OUTPUT TRAY AND PAPER SUPPORT WIRE

---

The machine ejects paper with printed surfaces face down into the output tray at the front of the machine.

When the output tray is closed, the ejected paper comes out sheet by sheet through the slit at the front. When you open the tray, sheets can be stacked on the tray.

Follow these steps to open the output tray:

1. Pull the top of the tray down (①).
2. Extend the extension support wire (②), and extend the extension document support wire.(③)

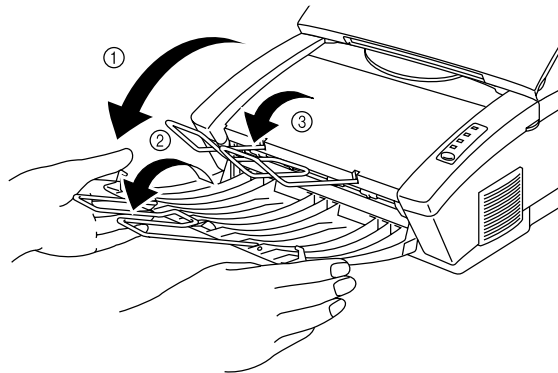

**Fig. 2-8 Opening the Output Tray and Extending the Extension Support Wire**

You can stack up to 100 sheets in the output tray.

**! Caution**

- When you use transparencies, remove each sheet immediately after printing. Stacking sheets may cause paper curled or paper jam.
- Continuous printing with the output tray closed may cause condensation inside the output tray.



## CHAPTER 3 PRINT

### LAMPS AND SWITCH

This section refers to the following lamps and switch on the machine control panel.

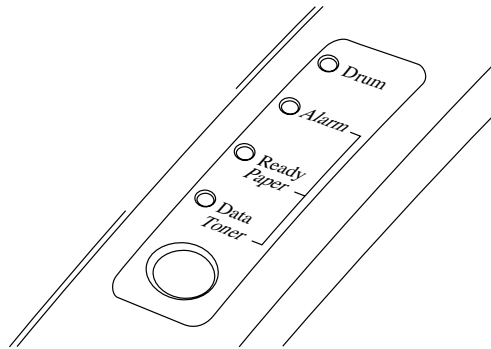

Fig. 3-1 Lamps and Switch on Control Panel

#### Note

When the **power** switch is off or the machine is in sleep mode, all lamps including the **Ready** lamp are off.

### Ready (Paper) Lamp

The **Ready** lamp indicates the current status of the machine.

Lamp	Machine status
Off ○	The <b>power</b> switch is off or the machine is in sleep mode. If the machine is in sleep mode, it will wake up automatically when it receives data or you press the control panel switch.
Blinking ○↔●	The machine is warming up. (Blinking at 1 second intervals)
Blinking ○↔●	The machine is cooling down and stops printing until the internal temperature lowers. (Blinking at 2 seconds intervals)
On ●	The machine is ready to print.

This lamp also works as the **Paper** lamp with the **Alarm** lamp. They blink simultaneously to indicate a paper error. See “Operator Calls” Chapter 7.

## Data (Toner) Lamp

The **Data** lamp indicates the current status of the print data process.

Lamp	Machine status
Off ○	The machine has no print data.
Blinking ○↔●	The machine is receiving data from the computer or is processing data in memory.
On ●	Print data remains in the machine memory. If the <b>Data</b> lamp is on for a long period of time and nothing has printed, you need to press the <b>switch</b> to print the remaining data.

This lamp also works as the **Toner** lamp with the **Alarm** lamp. They blink simultaneously to indicate a toner error. See [“REPLACING THE TONER CARTRIDGE”](#) in Chapter 6 and [“Operator Calls”](#) in Chapter 7.

## Drum Lamp

The **Drum** lamp indicates the drum unit is nearly at the end of its life.

Lamp	Machine status
Off ○	The drum unit can be used.
On ●	The drum unit is nearly at the end of its life. Installing a new drum unit turns off this lamp. See <a href="#">“REPLACING THE DRUM UNIT”</a> in Chapter 6.

## Alarm Lamp

The **Alarm** lamp blinks to indicate a machine error status such as “COVER OPEN” and “MEMORY FULL.” If any other error occurs, the machine indicates the error by blinking the **Alarm** lamp with another lamp or by printing an error report.

### Note

The **Ready**, **Data** and **Drum** lamps are used to indicate machine errors with the **Alarm** lamp. See [“ALARM INDICATIONS AT A GLANCE”](#) in Chapter 7 and take corrective action for the error.

## Switch

This **switch** will be used for the following purpose depending on the situation.

### Cancel printing

If you press the **switch** during printing, the machine immediately stops printing and ejects the paper.

### Wake-up

If the machine is in sleep mode, pressing the **switch** wakes it up into the ready state.

### Form Feed

If the **Data** lamp is on, press the **switch**. The machine prints any data remaining in memory: this operation is called "Form Feed."

### Error Recovery

If an error occurs, the machine will recover from some errors automatically. If the error does not clear automatically, press the **switch** to clear the error and continue machine operation.

## Other Control Features

The machine has the following useful features:

### Sleep Mode

When the machine does not receive data for a certain period of time (time-out), it enters sleep mode. Sleep mode acts as though the machine was turned off. The default time-out is 5 minutes. While the machine is in sleep mode, all the **lamps** are off and it is as if it was turned off, but the machine can still receive data from the computer. Receiving a print file or document automatically wakes up the machine to start printing. Pressing the **switch** also wakes up the machine.

#### Note

- When the machine goes into sleep mode, the fan will not stop until the machine engine has cooled down.
- Sleep mode allows the print engine to cool, so the temperature of your room and how long the machine has been in sleep mode affects the warm-up time. This warm-up time can take up to 30 seconds. The **Ready** lamp blinks to indicate that the machine is warming up.
- You can change the time out for the sleep mode with the supplied printer driver or Remote Printer Console program. Refer to the Help section in the printer driver or RPC program for more information about the sleep mode setting.

### Test Print Mode

The machine has the following test print mode. Follow these steps:

1. Make sure that the top cover is closed.
2. Hold down the switch and turn on the **power** switch. Keep the **switch** depressed until the **Drum** lamp comes on.

The **Drum** lamp lights to indicate that the machine is in the test print mode.

3. Press the **switch** again to execute the test print or hold down the **switch** to select another option and release the **switch** to execute the selected option.

The test print modes are listed below:

<b>Lamp Lit</b>	<b>Choice</b>	<b>Function</b>
<b>Drum</b>	Test sample page	The machine prints a test sample page. The machine returns to the ready status after printing.
<b>Alarm</b>	Print Config & Print Fonts I	The machine prints the current configuration of the machine and a list of the internal fonts. The machine returns to the ready status after printing.
<b>Ready</b>	Factory Reset	The machine is restored to the factory setting and permanent fonts and macros are cleared. The machine returns to the ready status after printing.
<b>Data</b>	Hex Dump Print	The machine can print data as hexadecimal values, so that you can check data errors and problems. To exit from this mode, you have to turn off the machine.

## CHAPTER 4 COPY

The machine allows you to make high-quality photocopies. Always make sure that paper is loaded in the Sheet Feeder before making copies.

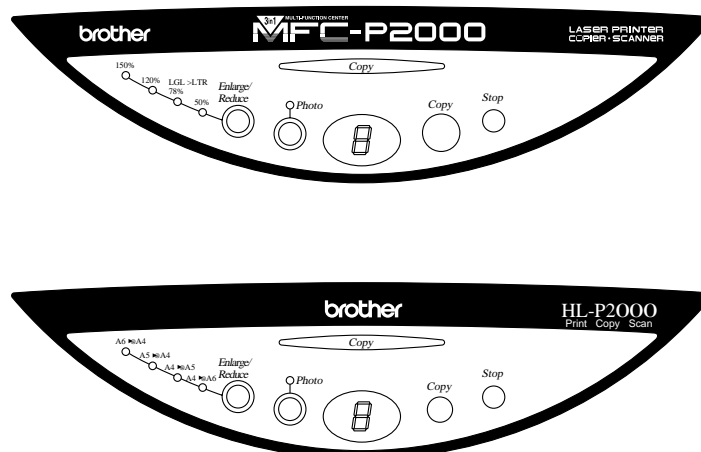

Fig. 4-1 Control Panel for Copying and Scanning Functions

### COPYING IN STANDARD MODE

1. Insert the original document face down in the Document Feeder.
2. Press the **Copy** button.

To stop copying, press the **Stop** button. The machine shows “E” on the display. Press the **Stop** button again to eject the original document.

### TO MAKE SETTINGS FOR EACH COPY

You can make various settings. These settings are effective only for the next copy and after that the settings are cleared. The number of copies should be set after Enlarge/Reduce and Quality settings have been made.

- **Enlarge/Reduce** - Enlargement / Reduction ratio
- **Photo/Text** - Copy output mode
- **Copies** - the number of copies

## Photo/Text

Select the copy mode from Text or Photo

1. Insert the original document face down in the Document Feeder.
2. Press the **Photo** button to select photo mode.  
When you select Photo mode, the **Photo** lamp comes on.
3. Press the **Copy** button to start copying.

## Enlarge/Reduce

You can make an enlarged or reduced size of copy from 50% to 150% (for USA and Canada), 50% to 200% (for other countries).

1. Insert the original document face down in the Document Feeder.
2. Press the **Enlarge/Reduce** button and select the Enlarge/Reduce ratio.

<For USA and Canada>

\* You can reduce to 78 or 50% of the original size.

---- OR ----

\* You can enlarge to 120% or 150%

<For other countries>

\* You can reduce to 71 or 50% of the original size.

---- OR ----

\* You can enlarge to 141% or 200%

When Enlarge/Reduce is 100%, all the LEDs are off.

3. Press the **Copy** button to start the copy.

### **Note**

If the enlarged size is bigger than the copy paper, you may lose some portion of the original document. In that case, reduce the enlargement ratio.

The Enlarge/Reduce function works as shown in the figure below.

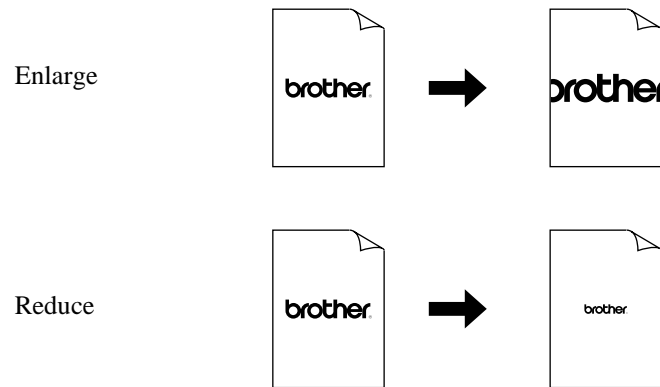

Fig. 4-2 Enlarge and Reduce

## The Number of Copies

You can make multiple copies.

1. Insert the original document face down in the Document Feeder.
2. Press the **Copy** button.
3. Press the **Copy** button again within one second if you want to increase the number of copies.

**Note**  
The maximum number of copies is 9.

## Error

If an error occurs, the machine shows "E" on the display.

To clear the error, press the **Stop** button.

An error will occur when the following happens;

- \*When the document causes a paper jam in the document feeder while the machine is feeding the document.
- \*When the machine is busy. (When the machine is being used as a scanner or printer.)
- \*When there is no paper in the sheet feeder.
- \*When memory full happens and the machine prints out an error message.

When there is no document in the Document Feeder when you try to copying, the machine shows the number of copies and the letter "P" alternately on the display. When you see this, insert a document in the Document Feeder.

### **Note**

When a memory full error is likely to happen, the machine changes the vertical resolution from 600 dpi to 300 dpi and copies the document automatically. In this case, the machine displays "F" on the display.



## CHAPTER 5 SCAN

The machine provides you with a TWAIN compliant scanner driver. This allows you to use the machine as scanner from any TWAIN compliant application such as Adobe Photoshop.

### SCANNING FROM TWAIN COMPLIANT APPLICATIONS

1. Launch the application you wish to use.
2. Select the 'Select Source' menu.

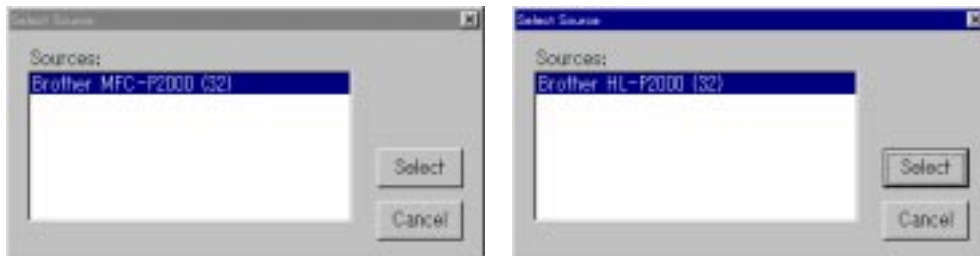

3. Select the "Brother MFC-P2000" or "Brother HL-P2000" and click Select.
4. Select the "Acquire" menu.
5. Make the appropriate settings such as;
  - Scanning Resolution
  - Photo, Text
  - Scanning Area
  - etc.....
6. Click the Start button.

#### Note

- Selecting the scanning area exactly reduces the scanning data so that you can save transfer time and memory.
- Generally, the scanning resolution should be set according to the final output device. For example, when the output device is a monitor screen, 150 dpi scanning is enough. If a higher resolution is chosen, the displayed output may not have any particular improvement.

## SCANNING FROM THE VISIONEER PaperPort® LE SOFTWARE (MFC-P2000)

---

1. Launch the Visioneer PaperPort® LE application.

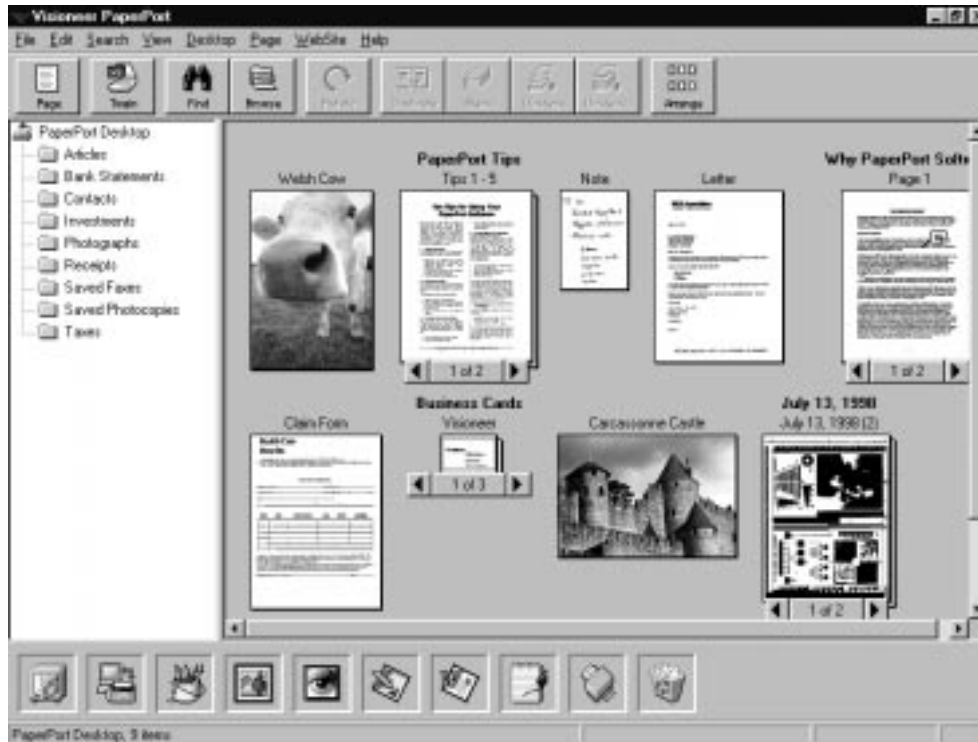

2. Click the Scan icon.  
The scanner driver dialog is launched.
3. Make the necessary settings.
4. Press the Start button.

The scanned image will be shown on the desktop with the name 'Untitled-x.'

For further information about 'PaperPort', refer to the On-line Help in the application.

## Scanning from the Unimessage™ Viewer Software (HL-P2000 - Windows® 95/98/NT users)

---

1. Launch the Unimessage™ Viewer application.
2. Select “Scan”.
3. After inserting the original document in the document feeder, click the “Start” button.

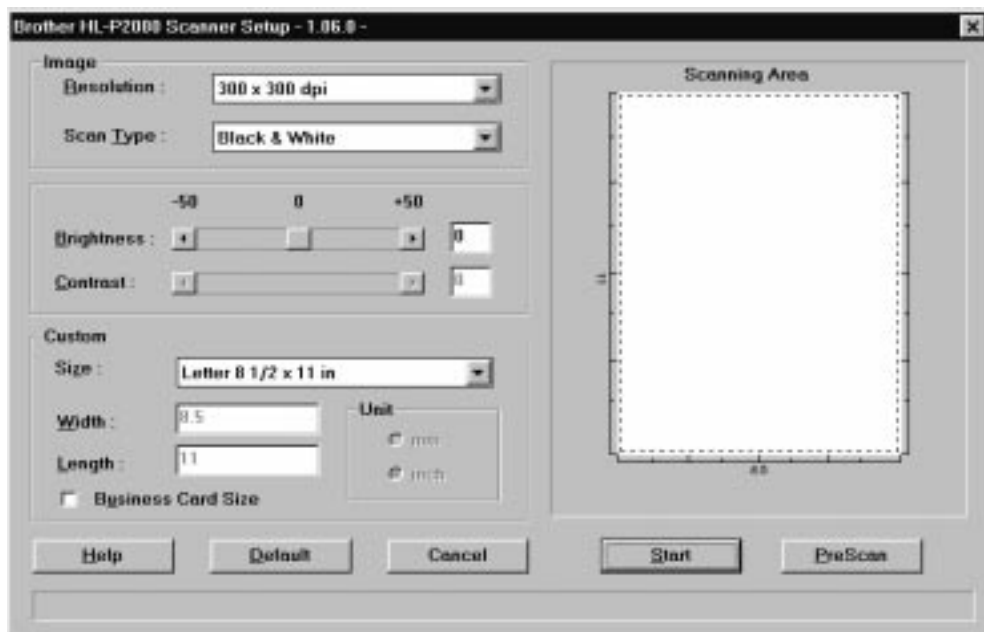

4. After the document has scanned completely, the “Collate Dialog” appears. Select the data you have just scanned and press “Add” button.
5. Click the “OK” button.

The scanned image will be shown on the desktop.

For further information about ‘Unimessage™ Viewer’, refer to the On-line Help in the application.

## CHAPTER 6 MAINTENANCE

### REPLACING THE TONER CARTRIDGE

The machine can print approximately 2,400 pages (5% coverage: A4/Letter) with one toner cartridge. When the toner cartridge is running low, the **Alarm** and **Data** (Toner) lamps blink once every 5 seconds to indicate toner low. **Initially, some models are supplied with a starter toner cartridge which must be replaced after 1,000 pages.**

#### Note

- Actual page count will vary depending on your average document type. (i.e.: standard letter, detailed graphics, etc.)
- It is recommended that you always keep a new toner cartridge ready for use for when you get the toner low warning.
- Discard the used toner cartridge according to local regulations. If you are not sure of them, consult your local dealer. Be sure to seal up the toner cartridge tightly so that toner powder does not spill out of the cartridge. Do not discard used toner cartridges together with domestic rubbish.
- It is recommended that you clean the machine when you replace the toner cartridge. See **“CLEANING THE MACHINE”** in this chapter.

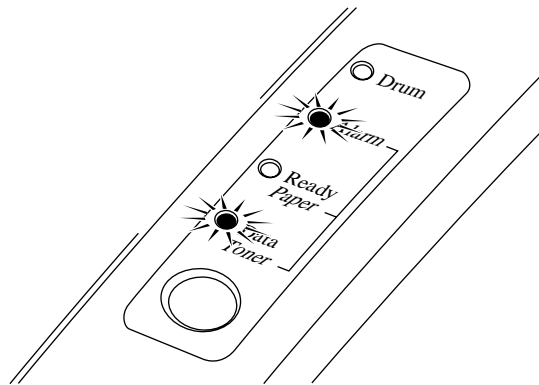

Fig. 6-1 Toner Low and Empty Indication

#### Caution

You may print approximately 100 pages after the first toner low indication. Both **Alarm** and **Data** (Toner) lamps will blink continuously to indicate that the toner is empty. Once this indication appears, your machine cannot resume printing until you have installed a new toner cartridge.

**!** **Caution**

**Keep the drum unit level after removing the toner cartridge, to avoid possible toner spill or scatter.**

Follow these steps to replace the toner cartridge:

1. Open the top cover towards you. Remove the drum unit by holding each side of the drum and gently lifting the drum forwards towards you.

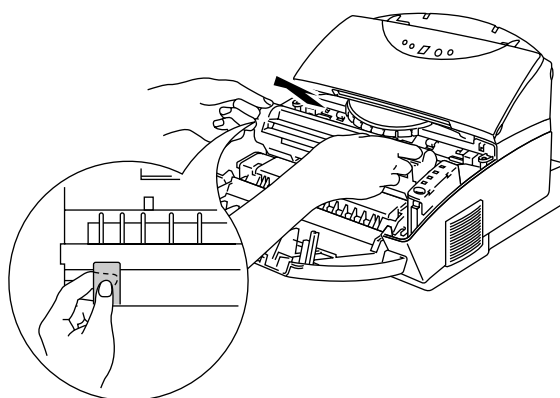

**Fig. 6-2 Removing the Drum Unit**

**✍ Note**

It is recommended to put the drum unit on a piece of disposable paper or cloth in case of accidental toner spill or scatter.

**⚠ Warning**

After you have just used the machine, some internal parts of the machine are extremely hot. When you open the top cover of the machine, never touch the shaded parts shown in the following illustration.

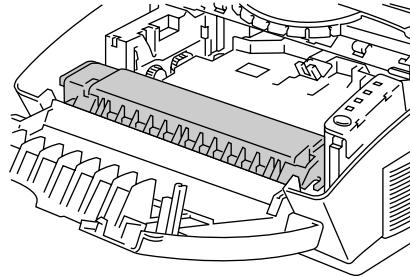

**⚠ High Temperature**

Fig. 6-3 Inside the Machine

2. Gently turn the lever on the toner cartridge forward until it stops.

**🔧 Note**

The toner cartridge cannot be removed unless the shutter is completely closed by turning the lever fully to the front.

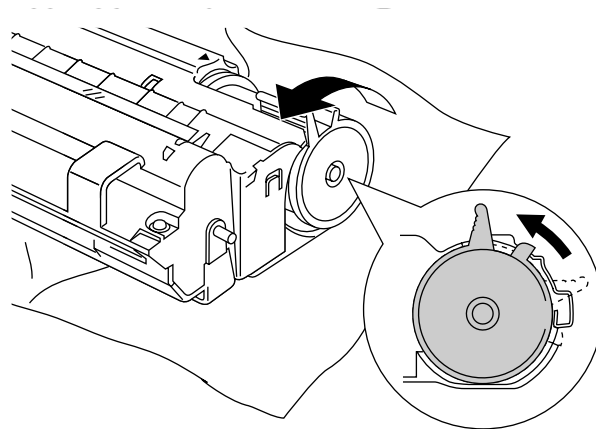

Fig. 6-4 Turning the Lever to Close the Shutter

3. Remove the old toner cartridge from the drum unit by pulling it out gently.

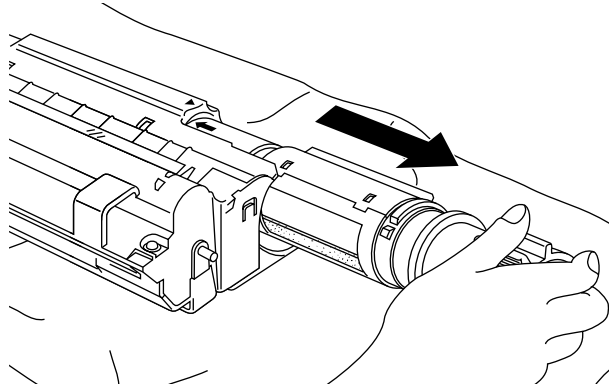

Fig. 6-5 Removing the Old Toner Cartridge

**Caution**

Handle the toner cartridge carefully. If toner scatters on your hands or clothes, wipe or wash it off with cold water immediately.

4. Unpack the new toner cartridge, gently shake it five or six times and then remove the protective part.

**Caution**

- Only unpack the toner cartridge immediately before installing it into the machine. If toner cartridges are left unpacked for a long period of time, the toner life is shortened.
- **You can only use a Brother genuine toner cartridge (TN-300 series) which is specially formulated to ensure top print quality. Damage caused by using toner cartridges other than those supplied by Brother is not covered under any warranty or service agreement.**

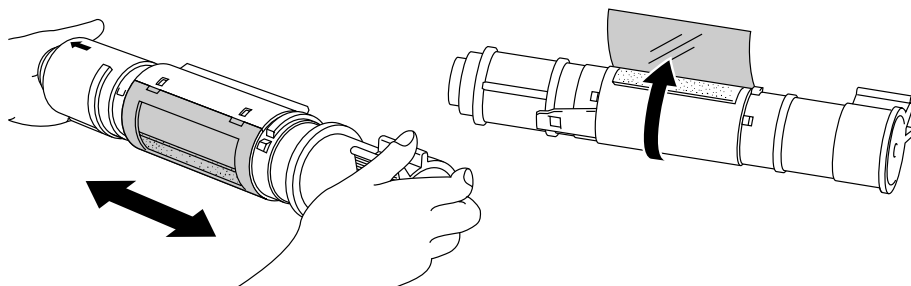
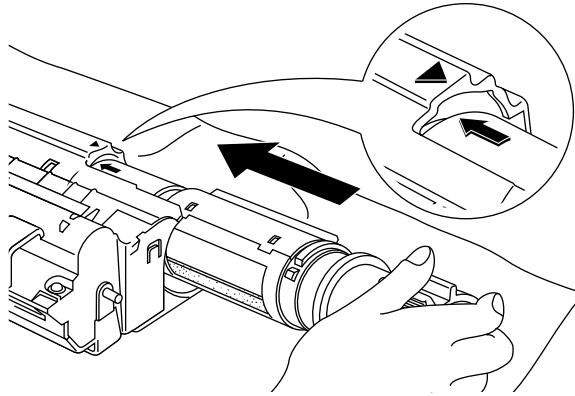

Fig. 6-6 Shaking the Toner Cartridge and Remove the Protective Part

5. Install the new toner cartridge into the right hand side of the drum unit. Make sure that the toner cartridge guide bar is exactly aligned with the guide slot in the drum unit and pushed fully home into the drum unit to ensure that the toner cartridge and the drum unit fit together correctly.



**Fig. 6-7 Installing the Toner Cartridge into the Drum Unit**

6. Gently turn the lever on the toner cartridge backward until it stops.

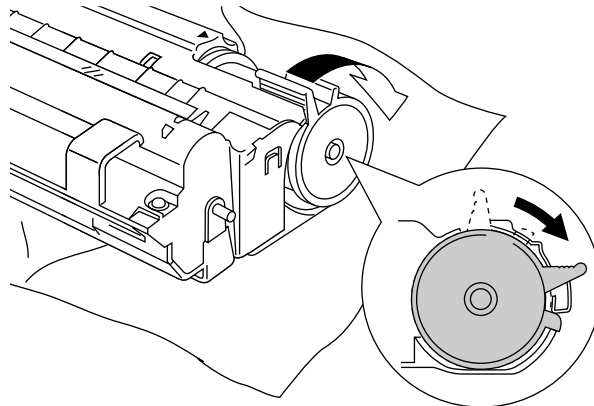
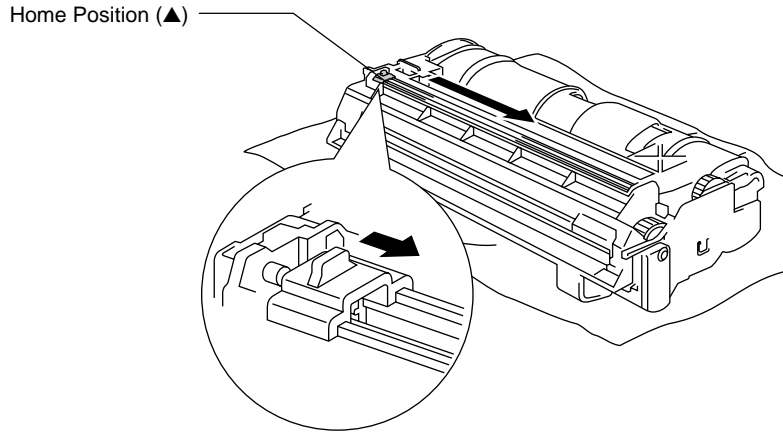

**Fig. 6-8 Turning the Lever to Open the Shutter**

7. Turn the drum unit upside down gently.



8. Clean the primary corona wire inside the drum unit by gently sliding the blue tab to the right and left several times.



**Fig. 6-9 Cleaning the Primary Corona Wire**

9. Re-install the drum unit into the machine and close the top cover.

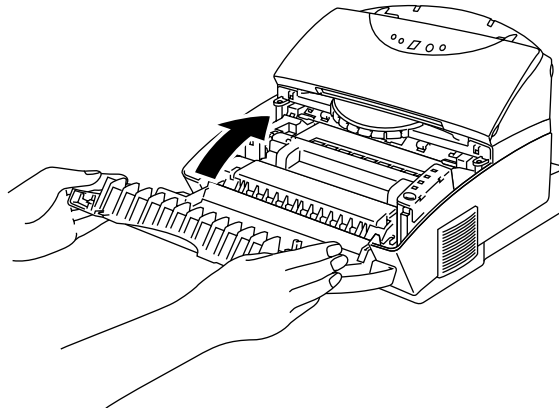

**Fig. 6-10 Close the top cover**

## REPLACING THE DRUM UNIT

The machine uses a drum unit to create the print images on paper. If the **Drum** lamp is on, it indicates the drum unit is nearly at the end of its life. We recommend you prepare a new drum unit to replace the current one. Even if the **Drum** lamp is on, you may be able to continue to print without replacing the drum unit for a while. If there is a noticeable deterioration in the output print quality even before the **Drum** lamp lights, then the drum unit should be replaced.

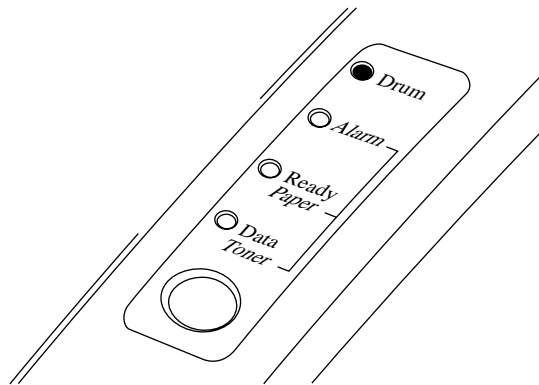

Fig. 6-11 Drum Unit Nearly at the End of its Life

### ⚠ Caution

- When removing the drum unit, handle it carefully as it contains toner.
- You should clean the machine when you replace the drum unit. See “CLEANING THE MACHINE” in this chapter.

### ✍ Note

The drum unit is a consumable, and it is necessary to replace it periodically.

There are many factors that determine the actual drum life, such as temperature, humidity, type of paper and toner that you use, the number of pages per print job, etc.. The drum life is estimated at approximately 20,000 pages at 20 pages per job and 8,000 pages at 1 page per job. The actual number of pages that your drum will print may be significantly less than these estimates. Because we have no control over the many factors that determine the actual drum life, we cannot guarantee a minimum number of pages that will be printed by your drum.

For best performance, use only genuine Brother toner and use the product in a clean, dust-free environment with adequate ventilation.

Follow these steps to replace the drum unit:

1. Open the top cover towards you. Remove the old drum unit.

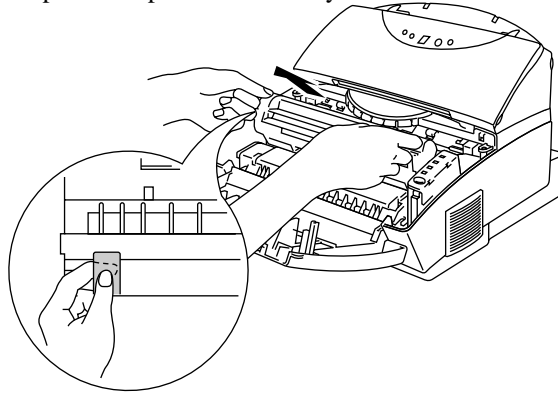
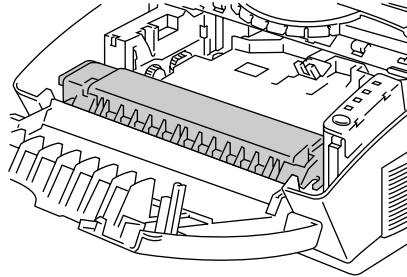

Fig. 6-12 Removing the Drum Unit

**Warning**

After you have just used the machine, some internal parts of the machine are extremely hot. When you open the top cover of the machine, never touch the shaded parts shown in the following illustration.



**High Temperature**

Fig. 6-13 Inside the Machine

2. Remove the toner cartridge from the drum unit and keep it in a safe place. For more information, see [“REPLACING THE TONER CARTRIDGE”](#) in this chapter.

**Note**

- Discard the used drum unit according to local regulations. If you are not sure of them, consult your local dealer/retailer. Be sure to seal up the drum unit tightly so that toner powder does not spill out of the unit. Do not discard used drum units together with domestic rubbish.
- It is recommended to put the drum unit on a piece of disposable paper or cloth in case of accidental toner spill or scatter.

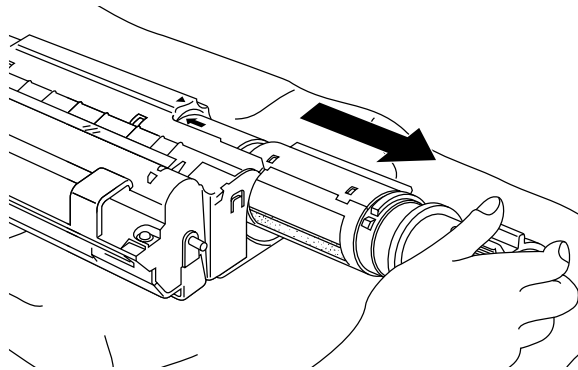

**Fig. 6-14 Removing the Toner Cartridge**

3. Unpack the drum unit and gently shake it five or six times horizontally.

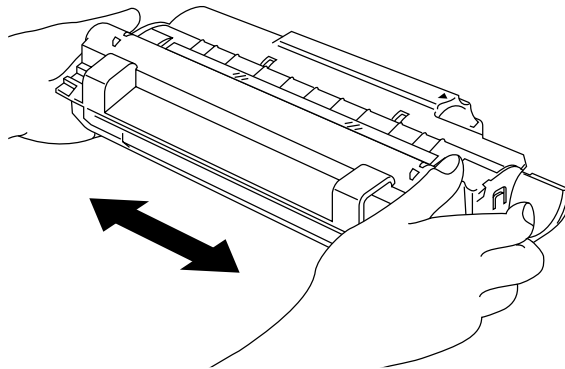

**Fig. 6-15 Shaking the Drum Unit**

**⚠ Caution**

- Do not remove the starter sheet.

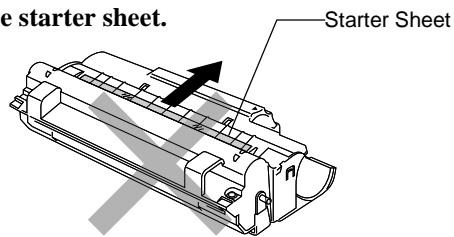

**Fig. 6-16 Do Not Remove the Starter Sheet**

- Only unpack a drum unit immediately before installing it into the machine. If an unpacked drum unit is subjected to excessive direct sunlight or room light, the unit may be damaged.
- Handle the toner cartridge and the drum unit carefully as it contains toner. If toner scatters and your hands or clothes get dirty, wipe or wash it off with cold water immediately.

4. Install the toner cartridge into the new drum unit. For more information, see ["REPLACING THE TONER CARTRIDGE"](#) in this chapter.
5. Install the new drum unit into the machine.

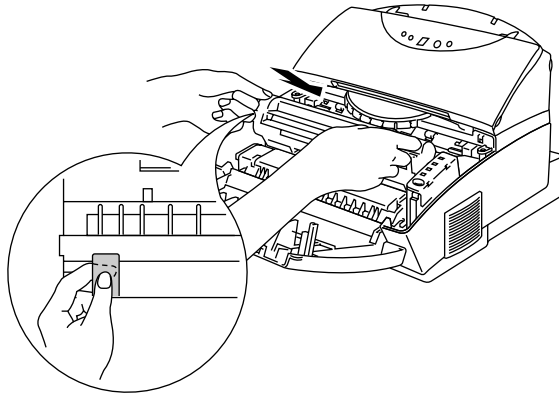

**Fig. 6-17 Installing the Drum Unit**

6. Close the top cover.
7. The machine automatically ejects the starter sheet. Ejecting this sheet resets the drum life alarm.

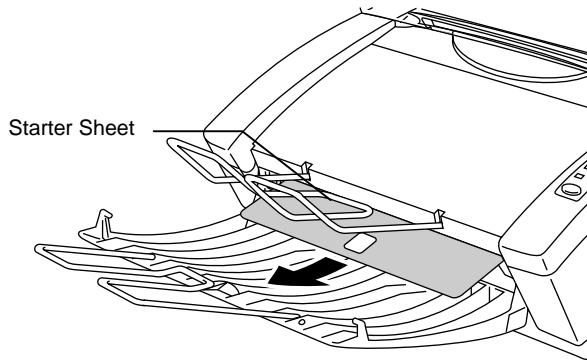

**Fig. 6-18 Ejecting the Starter Sheet**

## CLEANING THE MACHINE

---

Clean the machine exterior and interior periodically. If printed pages get stained with toner, clean the machine interior and drum unit.

### Cleaning the Machine Exterior

Clean the machine exterior as follows:

1. Turn off the **power** switch and unplug the power cord.

 **Warning**  
There are high voltage electrodes inside the machine. Before cleaning the machine, make sure to turn off the power switch and unplug the power cord from the power outlet

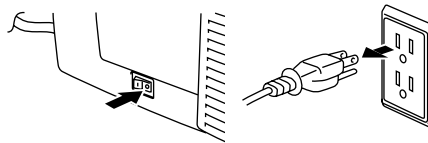

Fig. 6-19 Turning off the Switch and Unplugging

2. Remove the paper in the multi-purpose sheet feeder.
3. Use a damp cloth for cleaning.

 **Caution**

Use water or neutral detergents for cleaning. Cleaning with volatile liquids such as thinners or benzene will damage the surface of the machine.

4. Wipe dirt and dust away from the machine exterior and feeder with a cloth.
5. Load paper into the multi-purpose sheet feeder, and plug in the power cord.

## Cleaning the Machine Interior and Drum Unit

Clean the machine interior and the drum unit as follows:

1. Turn off the **power** switch and unplug the power cord.

### **Warning**

There are high voltage electrodes inside the machine. Before cleaning the machine, make sure to turn off the power switch and unplug the power cord from the outlet

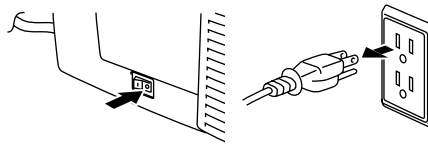
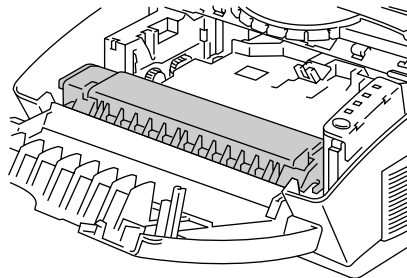

Fig. 6-20 Turning off the Switch and Unplugging

2. Open the top cover of the machine.
3. Take the drum unit out of the machine and put it aside.

### **Warning**

After you have just used the machine, some internal parts of the machine are extremely hot. When you open the top cover of the machine, never touch the shaded parts shown in the following illustration.



### **High Temperature**

Fig. 6-21 Inside the Machine

4. Gently wipe the scanner window with a soft dry cloth.

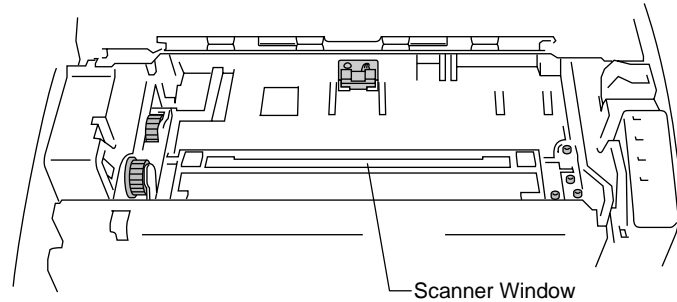

Fig. 6-22 Cleaning the Scanner Window

**⚠ Caution**

- Do not touch the scanner window with your fingers.
- Do not wipe the scanner window with cleaning alcohol.

5. Turn the drum unit upside down carefully.

**⚠ Caution**

Handle the drum unit carefully as it contains toner. If toner scatters and your hands or cloths get dirty, wipe or wash it off with cold water immediately.

**✍ Note**

It is recommended to put the drum unit on a piece of disposable paper or cloth in case of accidental toner spill or scatter.



6. Clean the primary corona wire inside the drum unit by gently sliding the tab to the right and left several times.

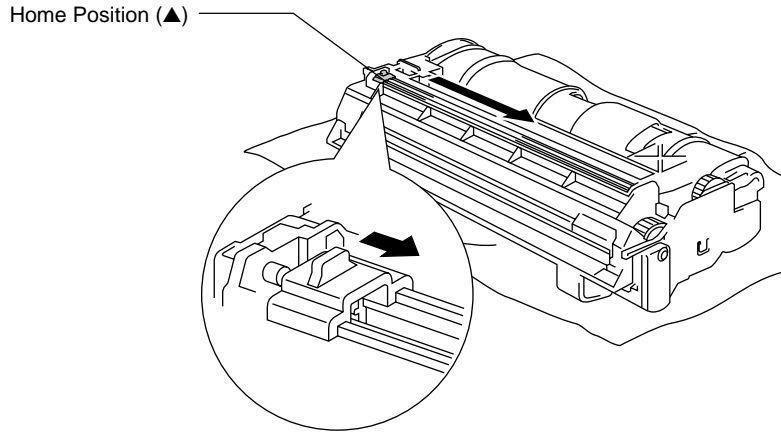

Fig. 6-23 Cleaning the Primary Corona Wire

7. Return the tab to the home position (▲ mark position) before reinstalling the drum unit.

**! Caution**

Be sure to position the tab at the home position, or printed pages may have vertical stripes.

8. Install the drum unit into the machine.  
*See the section "REPLACING THE DRUM UNIT" in this chapter.*
9. Close the top cover.
10. Plug in the power cord and turn on the **power** switch.

## Cleaning the Scanning Unit

Clean the scanning unit when you get stains on your copied document.

1. Turn off the **power** switch and unplug the power cord.
2. Open the document feeder.
3. Clean the flat white pressure bar and the glass strip under the bar with a dry cloth.

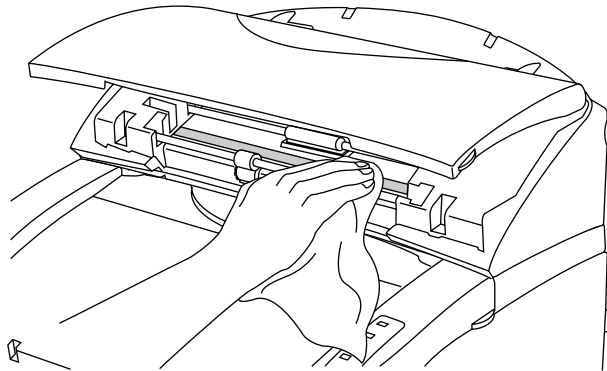

Fig. 6-24 Cleaning the Scanning Unit

4. Close the document feeder.
5. Plug in the power cord and turn on the **power** switch.

## RE-PACKING THE MACHINE

---

### ⚠ Caution

Whenever you transport the machine, use the packing materials which are provided with your machine. Also, follow the steps below to re-pack the machine, or it may be damaged which will void the machine warranty.

1. Turn off the **power** switch and unplug the machine from the AC outlet. Remove the AC cord and the extension wire of the paper tray from the machine.
2. Open the top cover.
3. Remove the drum unit assembly, referring to the previous section.

### ✍ Note

Remove the drum unit assembly with the toner cartridge included.

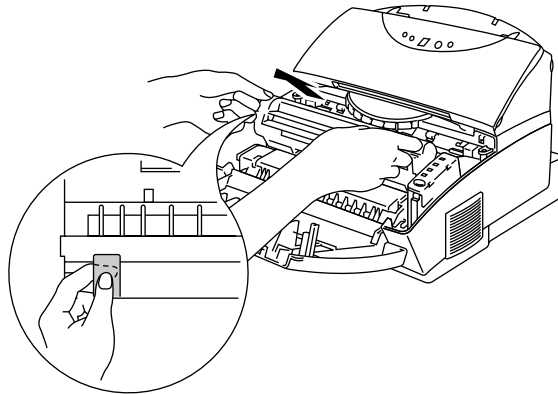
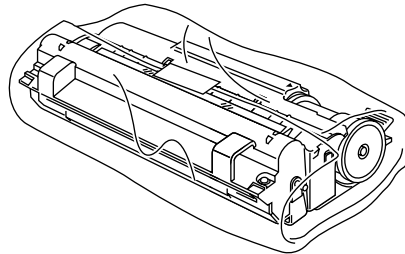

Fig. 6-25 Removing the Drum Unit Assembly

4. Place the drum unit assembly in the plastic bag and seal the bag completely.



**Fig. 6-26 Placing the Drum Unit in the Plastic Bag**

5. Close the top cover, the extension wire, and the output tray.
6. Remove the document support from the machine.
7. Wrap the machine in the plastic bag and place it in the original carton box with the original Styrofoam packing material.
8. Place any documents (manual and any documentation describing the reason for repacking the machine) and the drum unit assembly in the carton box as shown below.
9. Close the carton box and tape it.

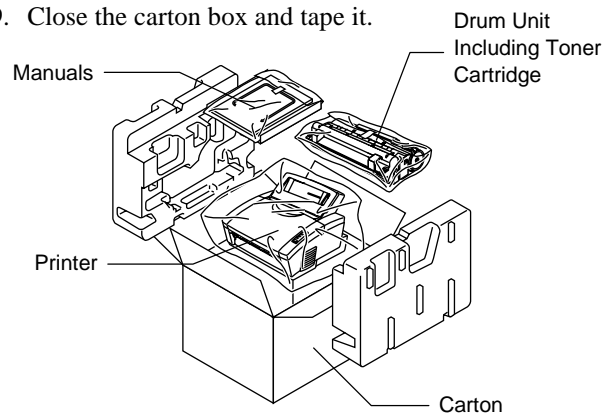

**Fig. 6-27 Repacking the Machine**

## CHAPTER 7 TROUBLESHOOTING

### ALARM INDICATIONS AT A GLANCE

#### Operator Calls for the Printing Function

If a recoverable error occurs, the machine indicates an ‘operator call’ by blinking the **Alarm** lamp and any of the following lamps.

Find the error and take the proper action to correct it. The machine automatically recovers from most errors, but you may need to reset the machine with the panel switch as described below.

Blinking Lamp	Error	Action
<b>Paper</b> ○↔● <b>Alarm</b> ○↔●	Paper jam	Clear the paper jam referring to the next section <b>“PAPER JAMS”</b> and press the panel <b>switch</b> if the machine does not automatically resume printing.
	Paper empty	Load paper in the machine referring to <b>Chapter 2</b> and press the panel <b>switch</b> .
	Misfeed	Reinstall the paper and press the panel <b>switch</b> .
<b>Toner</b> ○↔● <b>Alarm</b> ○↔● (every 5 seconds)	Toner low	Indicates that the machine has approximately 100 pages of printing left before the toner cartridge is empty. Prepare a new toner cartridge.
<b>Toner</b> ○↔● <b>Alarm</b> ○↔● (Fast blinking)	Toner Empty	Replace the toner cartridge with a new one referring to <b>Chapter 6</b> .

USER'S GUIDE

For errors shown below, the machine indicates an operator call by blinking the **Alarm** lamp. If you use the machine with the supplied Windows driver, the status monitor will appear to indicate the error on your computer screen. The machine also prints some error messages on paper.

Error	Action
COVER OPEN	Close the top cover of the machine.
PRINT OVERRUN	<ul style="list-style-type: none"><li>• Press the panel <b>switch</b> to print the data remaining in the machine.</li><li>• If you use the supplied Windows® driver, try again after turning on Error Recovery in the PRINT menu of your application software, (Refer to the Help section in the Windows® machine driver for the details.)</li><li>• If this does not clear the error, reduce the complexity of your document or reduce the print resolution.</li></ul>
MEMORY FULL  This error can only occur when using DOS.	<ul style="list-style-type: none"><li>• Press the panel <b>switch</b> to print the data remaining in the machine.</li><li>• Reduce the print resolution or reduce the complexity of your document.</li><li>•</li></ul>
Parallel Interface Line Error	<ul style="list-style-type: none"><li>• Press the panel <b>switch</b> to resume printing.</li><li>• Check that the connection between your computer and machine is secure and correct, and check the interface cable.</li></ul>

 **Note**

If the machine does not operate as you expect it to, it is recommended that you turn off the **power** switch, wait a few seconds and then turn it on again. If you still have problems, consult your dealer or our authorized service representative.

## Operator Calls for the Copying and Scanning Functions

If a recoverable error occurs, the machine shows “E” on the display.

To clear the error, press the Stop Button.

An error will occur when the following happens;

- \* When the document causes a paper jam in the document feeder while the machine is feeding the document.
- \* When the machine is busy. (When the machine is being used as a scanner or printer.)
- \* When there is no paper in the sheet feeder.
- \* When memory full happens.

## Service Calls for the Printing Function

If an unrecoverable error occurs, the machine indicates the need for a service call by lighting **all the lamps** and then the following combination of lamps alternately:

Service Call	Fuser malfunction	Laser BD malfunction	Scanner malfunction	ROM error
<b>Drum</b>	●	○	●	○
<b>Alarm</b>	○	●	●	○
<b>Ready</b>	○	○	○	●
<b>Data</b>	○	○	○	○

Service Call	D-RAM error	Service A	Service B	Service C
<b>Drum</b>	●	○	●	○
<b>Alarm</b>	○	●	●	○
<b>Ready</b>	●	●	●	○
<b>Data</b>	○	○	○	●

Service Call	Service D	Service E0	Service E1	Service P
<b>Drum</b>	●	○	●	○
<b>Alarm</b>	○	●	●	○
<b>Ready</b>	○	○	○	●
<b>Data</b>	●	●	●	●

Service Call	NV-RAM error	CPU Runtime error
<b>Drum</b>	●	●
<b>Alarm</b>	○	●
<b>Ready</b>	●	●
<b>Data</b>	●	●

● ON ○ OFF

If you see any of these service call indications, turn off the **power** switch, wait a few seconds and then turn it on again and try to print again.

If you cannot clear the error and see the same service call indication after turning on the machine, consult your dealer or our authorized service representative. Report the error status and situation referring to the above table.

**Note**

Be sure that the top cover and the main controller board are firmly installed.



## **Service Calls for the Copying and Scanning Functions**

If an unrecoverable error occurs, the machine shows “E” and “0”, “1” or “2” on the display alternately. When this happens, turn off the power switch, wait a few seconds and then turn it on again and try again.

If you cannot clear the error and see the same service call indication after turning on the machine, consult your dealer or our authorized service representative. Report the error status and situation referring to the above information.

## PAPER JAMS

Before you can clear a paper jam error, you need to find the location of the paper jams. Locate the position referring to the following figure.

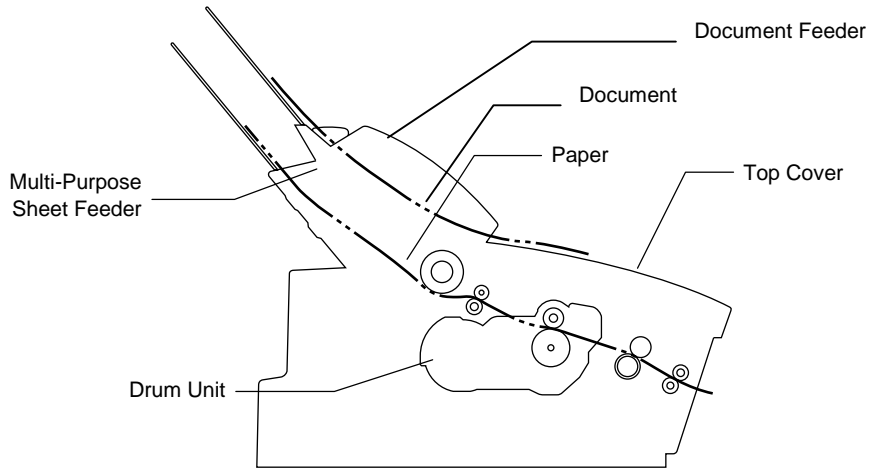
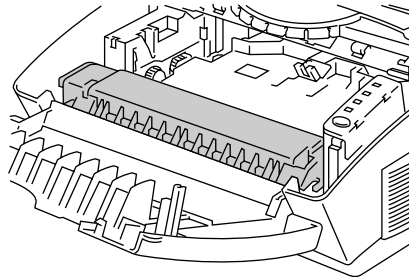

Fig. 7-1 Locating Paper Jam Position

After locating the position, clear the jammed paper referring to the following descriptions. If the jammed paper is removed completely and the top cover is closed, the machine may resume printing automatically. If the machine does not resume printing, press the control panel **switch**.

### **Warning**

After you have just used the machine, some internal parts of the machine are extremely hot. When you open the top cover of the machine, never touch the shaded parts shown in the following diagram.



### **High Temperature**

Fig. 7-2 Inside the Machine

**!** **Caution**

**Do not pull jammed paper from the output tray.** Be sure to open the top cover to remove the jam, or the fuser may get dirty with toner powder and may result in toner scatter on the next printed page or pages.

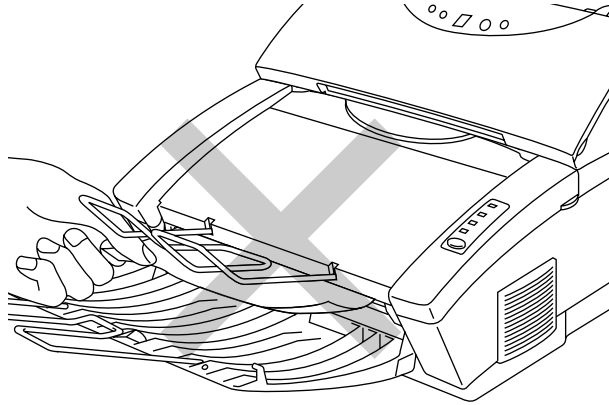

**Fig. 7-3 Do not pull the Jammed Paper from the Output Tray**

**□ Paper Jam in the Multi-Purpose Sheet Feeder**

If a paper jam has occurred inside the multi-purpose sheet feeder, open the multi-purpose sheet feeder to pull the jammed paper upward out of the feeder; then close the multi-purpose sheet feeder. Also, open the top cover and check that a torn piece of paper does not remain inside the machine referring to the next section.

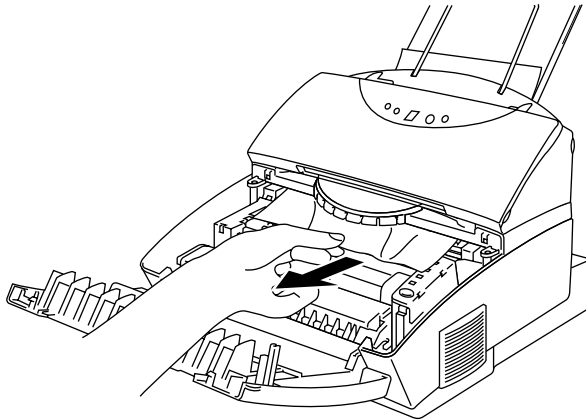

**Fig. 7-4 Paper Jam in the Feeder**

If the paper cannot be pulled up, see the next section **“Paper Jam near the Drum Unit.”**

❑ Paper Jam near the Drum Unit or at the Paper Output Tray

If a paper jam has occurred near the drum unit, open the top cover and remove the drum unit. Then, pull the jammed paper upwards and out of the machine. Install the drum unit and close the top cover.



**Fig. 7-5 Paper Jam near the Drum Unit**

❑ Paper Jam in the Fuser Unit

If a paper jam has occurred in the fuser unit, open the top cover and remove the drum unit. Then, pull the jammed paper out of the fuser. Install the drum unit and close the top cover.

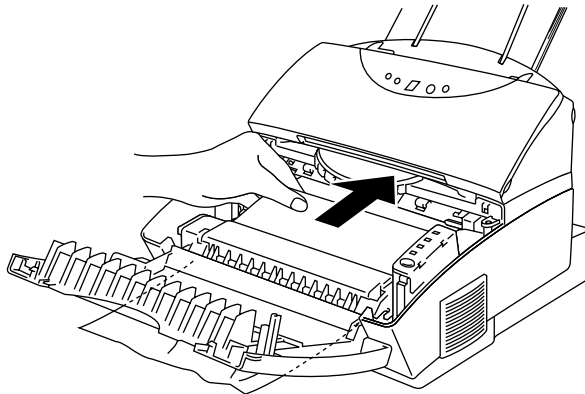

**Fig. 7-6 Paper Jam Inside the Machine**

❑ Paper Jam in the Document Feeder

If a paper jam has occurred in the document feeder, open the document feeder cover. Pull the jammed paper out of the document feeder towards you. After removing the document, close the document feeder.

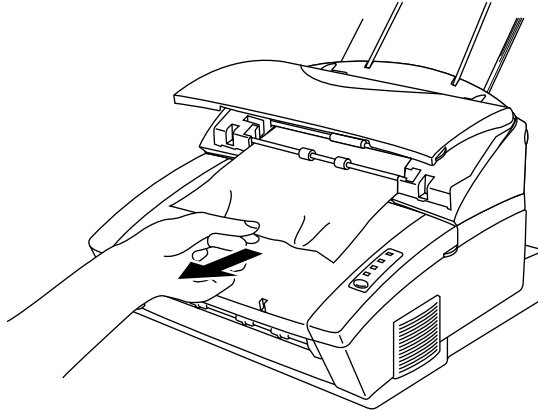

**Fig. 7-7 Paper Jam in the Document Feeder**

## Q & A

---

This section contains questions and answers for using your machine. If you have encountered a problem, find the question relating to your problem and take the steps recommended to correct the problem.

### Setting Up the Machine Hardware

Question	Recommendation
The machine does not work. All lamps are off.	The machine may be in sleep mode. Press the panel <b>switch</b> to wake up the machine. Check to see if the machine is plugged into a live power source and the <b>power switch</b> is on.
The machine does not print.	<p>Check the following:</p> <ul style="list-style-type: none"> <li>• The machine is turned on.</li> <li>• All of the protective parts have been removed.</li> <li>• The toner cartridge and drum unit are installed properly.</li> <li>• The interface cable is securely connected between the machine and computer.</li> <li>• Check to see if the <b>Alarm</b> lamp is blinking. If the lamp is blinking, refer to the Operator Call section of this manual.</li> <li>• Check to see if the <b>Ready</b> lamp is blinking. If the lamp is blinking fast, the machine might be cooling down to lower the machines internal temperature. Open the top cover of the machine to lower the temperature.</li> </ul>

### Setting Up the Machine for Windows

Question	Recommendation
I cannot print from my application software.	Make sure the supplied Windows printer driver is installed and selected with your application software.
Sometimes I get a Memory Full message. How can I correct this?	Reduce the print resolution or reduce the complexity of your document and try again.
Sometimes I get a Print Overrun error when printing certain documents from Windows.	<ul style="list-style-type: none"> <li>• If you are using the supplied Windows driver, turn error recovery on in the Setup dialog box and try again.</li> </ul> Reduce the print resolution or reduce the complexity of your document and try again.

## Setting Up the Machine for DOS

Question	Recommendation
I cannot print from my application software.	<ul style="list-style-type: none"> <li>• Check if the DOS application software interface settings match that of your machine: for example, if you are using a parallel printer cable, you would most likely set your DOS software printer port to LPT1.</li> <li>• Check if the machine has any alarms active. Check if the appropriate printer is selected in your application software.</li> </ul>
The machine prints, but it prints incorrect information. Sometimes it prints a couple of characters and then ejects the page, etc.	This is an indication that your application machine emulation setting and the machines emulation do not match. Check in your application software which printer you have selected to make sure the machine is set up correctly. Remember the machine emulates three widely used printer selections: HP LaserJet IIP, Epson FX-850, and IBM Proprinter XL. Try setting the printer into HP emulation and then select the HP LaserJet IIP printer in your application software.
The machine does not print when I press the Print Screen Key. (Data lamp On)	Press the panel <b>switch</b> . The data has been sent to the machine but the machine did not receive the Page Eject command: print screens do not send this command.
The machine prints the first part of my document but does not print the last page. (Data lamp On)	This was a common problem with database software and spreadsheet software when not correctly set up. The data has been sent to the machine but the machine did not receive the Page Eject command. Press the panel <b>switch</b> to eject the page. Then check with your software supplier on how to add a Page Eject (or Form Feed) command to the end of your print job.
How can I change the User settings or default settings of the machine?	Use the remote printer console (RPC) program.

## Paper Handling

Question	Recommendation
The machine does not load paper.	<ul style="list-style-type: none"> <li>• Check to see if the “PAPER EMPTY” message appears on your computer screen or the <b>Alarm</b> and <b>Paper</b> lamps are blinking on the machine control panel. If so, the multi-purpose sheet feeder may be out of paper or not properly installed. If it is empty, load a new stack of paper into the feeder.</li> <li>• If there is paper in the multi-purpose sheet feeder, make sure it is straight. If the paper is curled, you should straighten it before printing. Sometimes it is helpful to remove the paper, turn the stack over and put it back into the paper tray.</li> <li>• Reduce the amount of paper in the multi-purpose sheet feeder, then try again.</li> </ul>
How can I load envelopes?	You can load envelopes from either the multi-purpose sheet feeder or the manual feed slot. Your application software must be set up correctly to print on the envelope size you are using. This is usually done in the page setup or document setup menu of your software. Refer to your application manual.
What paper can I use?	You can use plain paper, envelopes, transparencies, labels, and organizer paper. For information on loading paper, see “Paper Handling” in Chapter 2.
How can I clear paper jams?	See “PAPER JAMS” in this chapter.



## Printing

Question	Recommendation
The machine prints unexpectedly or it prints garbage.	<ul style="list-style-type: none"> <li>• Turn the machine off and on again to reset the machine.</li> <li>• Make sure your application software is correctly set up to use this machine by checking the machine settings in your application software.</li> </ul> <p>Check the machine emulation settings. If you can use the supplied RPC program, use it to change the settings as required. Also, you can print the current setting list from the RPC program or Machine Control Panel.</p>
The machine cannot print full pages of a document. An error message "PRINT OVERRUN" occurs.	<p>The machine received a very complex print job and could not process part of the page. This may be solved by the following ways.</p> <ul style="list-style-type: none"> <li>• If you are using Windows 95 or Windows 3.1 with the supplied printer driver, see the "Setting up the Machine for Windows" section.</li> <li>• Try to reduce the complexity of your document or reduce the print resolution.</li> </ul>
The machine cannot print full pages of a document. A "MEMORY FULL" error message occurs.	<ul style="list-style-type: none"> <li>• Reduce the graphic quality or the number of font sizes within your application software.</li> <li>• Reduce the print resolution.</li> <li>• Reduce the complexity of your document and try again.</li> </ul>
The machine cannot print full pages of a document. A "MEMORY FULL" error message occurs.	<ul style="list-style-type: none"> <li>• Reduce the print resolution.</li> <li>• Reduce the complexity of your document and try again.</li> <li>• Reduce the graphic quality or the number of font sizes within your application software.</li> </ul>
My headers or footers appear when I view my document on screen but do not show up when I print them.	<p>Most laser printers have a restricted area that cannot be printed on. Usually the first two lines and last two lines of text cannot print (leaving 62 printable lines). Adjust the top and bottom margins in your document to allow for this.</p>

## Copy

Question	Recommendation
The machine does not copy.	<p>Check the following;</p> <ul style="list-style-type: none"> <li>• The machine is turned on.</li> <li>• All of the protective parts have been removed.</li> <li>• The top cover is closed.</li> <li>• The <b>Alarm</b> LED is blinking. If the LED is blinking, refer to the Operator Calls section of this manual.</li> </ul>
The machine copies, but nothing is printed on the copy.	<p>check if;</p> <ul style="list-style-type: none"> <li>• Original documents are inserted face down in the document feeder.</li> <li>• The toner cartridge is not empty.</li> </ul>
Copy has a vertical line.	<p>Clean the scanning unit referring to 'Cleaning the Scanning Unit' section in Chapter 6.</p>
Some portion of the image is missing on the copy.	<ul style="list-style-type: none"> <li>• The machine has unscannable and unprintable areas. Check the areas in Chapter 2.</li> <li>• If the image is larger than the paper size, it may be lost.</li> </ul>
Memory full error.	<ul style="list-style-type: none"> <li>• A DOS application is using download fonts and the memory is almost full.</li> <li>• After a memory full error occurs, the machine clears any downloaded fonts automatically.</li> </ul>

## Scan



Question	Recommendation
The machine does not scan	<p>Check the following;</p> <ul style="list-style-type: none"> <li>• The machine is turned on.</li> <li>• All of the protective parts have been removed.</li> <li>• The top cover is closed.</li> </ul>
Computer indicates an error message other than above.	<p>Check the following;</p> <ul style="list-style-type: none"> <li>• The machine is connected directly to the computer.</li> <li>• The computer can work in bi-directional mode.</li> <li>• The scanner port is correctly set on your computer.</li> <li>• The Scanner driver is correctly selected in your application.</li> <li>• A recommended interface cable is being used.(IEEE 1284 compliant)</li> </ul>
Scanned image has vertical white or black line.	<p>Clean the scanning unit.</p>

## Print Quality

**! Caution**

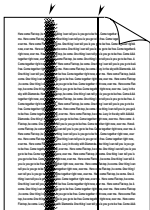
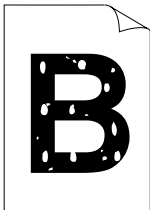
You will clear a print quality problem by replacing the drum unit with a new one **if the Drum lamp is on**. The drum unit is at the end of its life.

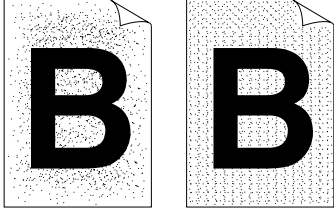
Question	Recommendation
<p>Printed pages contain white stripes.</p>  <p><b>Fig. 7-8 White Stripes or Faint Images</b></p>	<p>You may clear the problem by wiping the scanner windows with a soft cloth. (See “Cleaning the machine interior and Drum unit.” in Chapter 6.)</p> <p>If the same problem occurs and the <b>Drum lamp</b> is still on after cleaning, replace the drum unit with a new one.</p>
<p>Printed pages are stained with toner or have vertical stripes.</p>  <p><b>Fig. 7-9 Dark Stripes or Toner Stains</b></p>	<ul style="list-style-type: none"> <li>• Clean the machine interior and the primary corona wire of the drum unit. See “Cleaning the Machine Interior and Drum Unit” in Chapter 6.</li> <li>• Make sure that the tab of the corona wire is at the home position.</li> </ul> <p>If the same print problem occurs and the <b>Drum lamp</b> is still on after cleaning, replace the drum unit with a new one.</p>
<p>Printed pages have white spots in black text and graphics area.</p>  <p><b>Fig. 7-10 White Spots</b></p>	<p>Make sure that you use paper that meets the specifications. Rough surface or thick media can cause the problem.</p> <p>If you still have the same problem and the <b>Drum lamp</b> is on, replace the drum unit with a new one.</p>

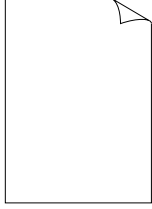
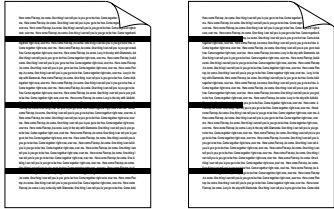
Question	Recommendation
<p>Toner scatters and stains the printed page.</p>  <p><b>Fig. 7-11 Scattering Toner</b></p>	<p>Clean the machine interior. See <a href="#">“Cleaning the Machine Interior and Drum Unit”</a> in Chapter 6.</p> <p>Make sure that you use paper that meets specifications.</p> <p>After the new toner cartridge is installed, the first 10 - 20 pages may be stained with toner. This problem will be cleared after the first 10-20 pages with the new toner cartridge.</p> <p>If you still have the same problem and the <b>Drum</b> lamp is on, replace the drum unit with a new one.</p>
<p>The whole page is printed in black.</p>  <p><b>Fig. 7-12 Black Page</b></p>	<p>If the same problem occurs and the <b>Drum</b> lamp is still on after cleaning, replace the drum unit with a new one.</p>
<p>Nothing is printed on the page.</p>  <p><b>Fig. 7-13 White Page</b></p>	<ul style="list-style-type: none"> <li>• Make sure that the toner cartridge is not empty.</li> <li>• Make sure that a torn piece of paper does not remain on the scanner window.</li> </ul>
<p>Printed pages are marked at regular intervals.</p>  <p><b>Fig. 7-14 Example of Regular Marking</b></p>	<p>The problem may disappear by itself. Try printing multiple pages to clear this problem especially if the machine has not been used for a long time.</p> <p>If the surface of the drum has been scratched, replace the drum unit with a new one.</p> <p>If the problem does not disappear, it may be that the drum has been marked or damaged due to excessive exposure to light. In this case, replace the drum unit with a new one.</p>

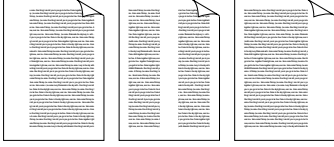
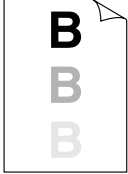
Question	Recommendation
<p>Printed pages are blurred at the center or either edge.</p>  <p><b>Fig. 7-15 Blurred Page</b></p>	<p>Certain environmental conditions such as humidity, high temperatures, etc. may cause this situation to occur.</p> <ul style="list-style-type: none"> <li>• Make sure that the machine is placed on a flat, horizontal surface.</li> <li>• Remove the drum unit with the toner cartridge installed. Try shaking them from side to side.</li> <li>• You may clear the problem by wiping the scanner window with a soft cloth. (See “Cleaning the Machine Interior and Drum Unit.”)</li> </ul> <p>If the same problem occurs after cleaning and <b>Drum</b> lamp is still on, replace the drum unit with a new one.</p>
<p>Ghost images show up on printed pages.</p>  <p><b>Fig. 7-16 Ghost Images</b></p>	<ul style="list-style-type: none"> <li>• Make sure that you use paper that meets the specifications. Rough surface or thick media can cause the problem.</li> <li>• Make sure that you select the appropriate media type in the printer driver.</li> </ul>

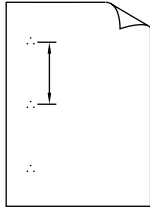
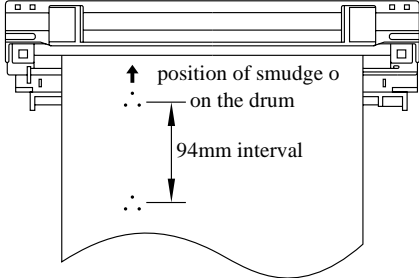
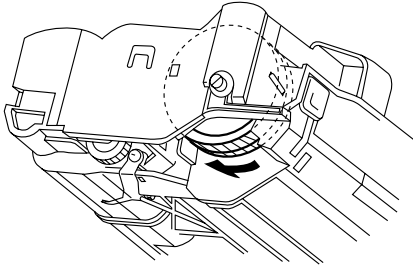
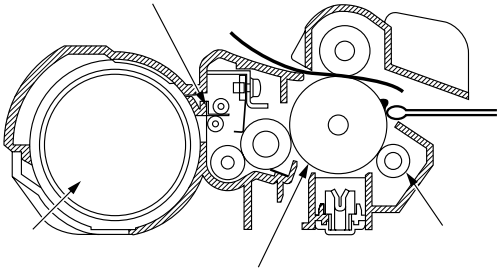
Question	Recommendation
<p>Black spots appears on the printed paper at 94mm intervals.</p>  <p><b>Fig. 7-17 Black Spots</b></p>	<p>If toner remains stuck on the drum, wipe it off gently with a cotton swab. Replace the drum unit if the drum is scratched or deteriorated.</p> <p>Clean the drum unit as follows;</p> <ol style="list-style-type: none"> <li>1. Place a printed page in front of the process unit, and find the exact position of the image defect.</li> </ol>  <p><b>Fig. 7-18</b></p> <ol style="list-style-type: none"> <li>2. Turn the drum gear by hand while looking at the surface of the drum until you find the cause of the problem.</li> </ol>  <p><b>Fig. 7-19</b></p> <ol style="list-style-type: none"> <li>3. Wipe the surface of the photosensitive drum with a cotton swab until the dust or paper on the surface of the drum comes off.</li> </ol>  <p><b>Fig. 7-20</b></p> <p>Do not wipe the surface of the photosensitive drum with something sharp. (ball-point pen etc.)</p>

**Note**

The drum unit is a consumable, and it is necessary to replace it periodically.

# APPENDIX

## PRINTER SPECIFICATIONS

---

### Printing

Print Method	Electrophotography by semiconductor laser beam scanning
Laser	Wavelength: 780 nm Output: 5 mW max
Resolution	600 dots/inch (under Brother Printing Solution for Windows <sup>®</sup> / under Brother Software PCL5e for DOS box in Windows <sup>®</sup> ) 300 dots/inch (under DOS)
Print Quality	Normal printing mode Economy printing mode (up to 25% and 50% toner saving)
Print Speed	Up to 10 pages/minute (when loading A4 or letter-size paper from the multi-purpose sheet feeder)  <b>NOTE:</b> Maximum print speed is obtained by printing several copies of the same page. Print speed may vary depending on interface type, emulation, processing power of the computer, memory allocated to the print job, paper size and graphic quality.
Warm-Up	Max. 30 seconds at 23°C (73.4°F) (The warm up time depends on the ambient temperature and humidity.)

## USER'S GUIDE

First Print	15 seconds (when loading A4 or letter-size paper from the multi-purpose sheet feeder)
Print Media	Toner cartridge: Life Expectancy: 2,400 pages/new toner cartridge 1,000 pages/starter toner cartridge (when printing A4- or letter-size paper at 5% print coverage) <b>NOTE:</b> Toner life expectancy will vary depending on the type of average print job printed.  Drum Unit: Life Expectancy: 20,000 pages at 20 pages per job 8,000 pages at 1 page per job  <b>NOTE:</b> There are many factors that determine the actual drum life, such as temperature, humidity, type of paper and toner that you use, the number of pages per print job, etc..

## Copying

Type	Auto Document Feeder
Resolution	300 x 300 dpi class: Photo mode, 200 x 600 dpi: Text mode
Enlarge/Reduce	For USA and Canada: 50%, 78%, 120% and 150% For other countries: 50%, 71%, 141% and 200%
Input	10 documents
Multi-copy	Yes

## Scanning

Resolution	600 x 600 dpi class with 256 levels of gray
Software	TWAIN driver Vioneer PaperPort® LE Software WordCraft Unimessage™ Viewer



## Functions

TrueType Fonts on disks	TrueType-compatible soft-fonts for Windows on the supplied disk
Emulation	Brother Printing Solution for Windows Automatic emulation selection among HP LaserJet IIP (PCL level 4), EPSON FX-850, or IBM Proprinter XL
Printer Driver	Windows® 3.1/3.11, Windows® 95 and Windows NT® 4.0 driver, supporting Brother Native Compression mode and bi-directional capability
Interface	Bi-directional parallel
Memory	2 MB
Diagnostics	Self-diagnostic program

## Electrical and Mechanical

Power Source	U.S.A. and Canada: AC 110 to 120 V, 50 / 60 Hz Europe and Australia: AC 220 to 240 V, 50 /60 Hz
Power Consumption	Printing: 280 W or less Stand-by: 60 W or less Sleep: 13 W or less Copying: 180W or less
Noise	Printing: 49 dB A or less Sleep: 33 dB A or less
Temperature	Operating: 10 to 32.5°C (50 to 90.5°F) Storage: 0 to 40°C (38 to 104°F)
Humidity	Operating: 20 to 80% (without condensation) Storage: 20 to 80% (without condensation)
Dimensions (W x H x D)	390 x 282 x 371 mm (14.4 x 11 x 14.5 inches) (when the output tray is closed.)
Weight	Approx. 8.5 kg (18.7 lb.) including the drum unit

## PARALLEL INTERFACE SPECIFICATIONS

**Note**

To ensure best quality performance use an IEEE 1284 compliant parallel cable between the printer and your computer. Only IEEE 1284 cables support all of the advanced printing capabilities, like bi-directional communication. These cables will be clearly marked with "IEEE-1284".

Interface Connector      Printer Side: Amphenol FCN-685J036-L/X or equivalent  
A shielded cable should be used.

Pin Assignment

Pin No.	Signal	Direction	Pin No.	Signal	Direction
1	<u>DATA STROBE</u>	Input	19	0V (S.G.)	–
2	DATA 1	Input/output	20	0V (S.G.)	–
3	DATA 2	Input/output	21	0V (S.G.)	–
4	DATA 3	Input/output	22	0V (S.G.)	–
5	DATA 4	Input/output	23	0V (S.G.)	–
6	DATA 5	Input/output	24	0V (S.G.)	–
7	DATA 6	Input/output	25	0V (S.G.)	–
8	DATA 7	Input/output	26	0V (S.G.)	–
9	DATA 8	Input/output	27	0V (S.G.)	–
10	<u>ACKNLG</u>	Output	28	0V (S.G.)	–
11	BUSY	Output	29	0V (S.G.)	–
12	PE	Output	30	0V (S.G.)	–
13	SLCT	Output	31	<u>INPUT PRIME</u>	Input
14	<u>AUTO FEED</u>	Input	32	<u>FAULT</u>	Output
15	N.C.	–	33	N.C.	–
16	0V (S.G.)	–	34	N.C.	–
17	0V (S.G.)	–	35	N.C.	–
18	+5V	–	36	<u>SLCT IN</u>	Input

**Note**  
To use bi-directional communication, an interface cable which has the pin connections above must be used.

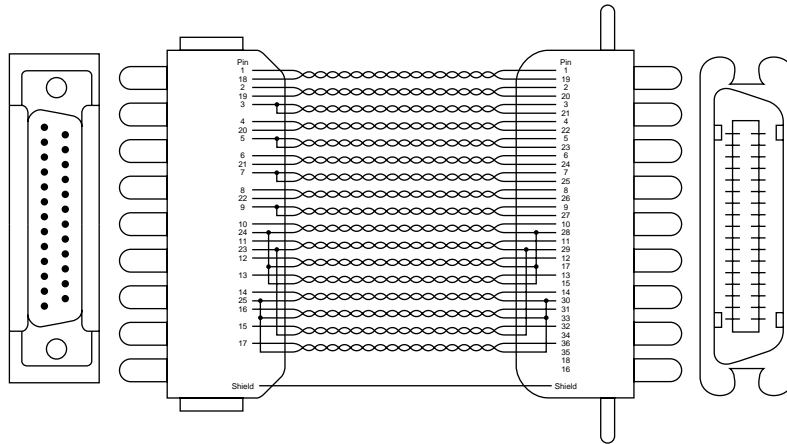

**Fig. A-1 Parallel Interface Cable**

## RESIDENT FONTS

---

The following bitmapped fonts are resident in this printer.

### Bitmapped Fonts

Brougham 10 (12 point)	upright/normal upright/bold italic/normal italic/bold
Brougham 12 (10 point)	upright/normal upright/bold italic/normal italic/bold
Letter Gothic 16.66 (8.5 point)	upright/normal upright/bold italic/normal italic/bold

(Portrait and Landscape are available for the above.)

## SYMBOL SETS/CHARACTER SETS

---

### HP LaserJet IIP Mode

- ISO14 JIS ASCII
- ISO57 Chinese
- ISO11 Swedish
- HP Spanish
- ISO17 Spanish
- ISO10 Swedish
- ISO16 Portuguese
- ISO84 Portuguese
- ISO85 Spanish
- PC-8
- PC-8 D/N
- PC-8 Turkish
- PC-850
- PC-852
- PC-860
- PC-863
- PC-865
- Roman 8
- ISO Latin 1 (ECMA-94)
- ISO60 Norwegian 1
- ISO61 Norwegian 2
- ISO4 UK
- ISO25 French
- ISO69 French
- HP German
- ISO21 German
- ISO15 Italian
- ISO6 ASCII
- Legal
- ISO2 IRV

### EPSON Mode

- US ASCII
- PC-8
- PC-8 D/N
- PC-850
- PC-852
- PC-860
- PC-863
- PC-865
- PC-8 Turkish
- German
- UK ASCII I
- French I
- Danish I
- Italy
- Spanish
- Swedish
- Japanese
- Norwegian
- Danish II
- UK ASCII II
- French II
- Dutch
- South African

### IBM Mode

- PC-8
- PC-8 D/N
- PC-850
- PC-852
- PC-860
- PC-863
- PC-865
- PC-8 Turkish

#### Note

If you want to know what characters are in each symbol/character set, print the CHARSETS.PRN file from the "Print form" option in the Direct Access Menu of the Remote Printer Console Program.

□ HP LaserJet IIP

Roman 8										ISO Latin1																					
0	1	2	3	4	5	6	7	8	9	A	B	C	D	E	F	0	1	2	3	4	5	6	7	8	9	A	B	C	D	E	F
0		0	@	P	'	p				À	Á	Â	Ã	Ä	Å	0		0	@	P	'	p				À	Á	Â	Ã	Ä	Å
1	!	1	A	Q	a	q				À	Á	Â	Ã	Ä	Å	1	!	1	A	Q	a	q				À	Á	Â	Ã	Ä	Å
2	"	2	B	R	b	r				À	Á	Â	Ã	Ä	Å	2	"	2	B	R	b	r				À	Á	Â	Ã	Ä	Å
3	#	3	C	S	c	s				È	É	Ê	Ë	Ì	Í	3	#	3	C	S	c	s				È	É	Ê	Ë	Ì	Í
4	\$	4	D	T	d	t				È	É	Ê	Ë	Ì	Í	4	\$	4	D	T	d	t				È	É	Ê	Ë	Ì	Í
5	%	5	E	U	e	u				È	É	Ê	Ë	Ì	Í	5	%	5	E	U	e	u				È	É	Ê	Ë	Ì	Í
6	&	6	F	V	f	v				Ï	Ñ	Ò	Ó	Ô	Õ	6	&	6	F	V	f	v				Ï	Ñ	Ò	Ó	Ô	Õ
7	'	7	G	W	g	w				Ï	Ñ	Ò	Ó	Ô	Õ	7	'	7	G	W	g	w				Ï	Ñ	Ò	Ó	Ô	Õ
8	(	8	H	X	h	x				ˆ	˜	¸	¸	¸	¸	8	(	8	H	X	h	x				ˆ	˜	¸	¸	¸	¸
9	*	9	I	Y	i	y				ˆ	˜	¸	¸	¸	¸	9	*	9	I	Y	i	y				ˆ	˜	¸	¸	¸	¸
A	*	:	J	Z	j	z				ˆ	˜	¸	¸	¸	¸	A	*	:	J	Z	j	z				ˆ	˜	¸	¸	¸	¸
B	+	;	K	[	k	{				ˆ	˜	¸	¸	¸	¸	B	+	;	K	[	k	{				ˆ	˜	¸	¸	¸	¸
C	,	<	L	\	l					ˆ	˜	¸	¸	¸	¸	C	,	<	L	\	l					ˆ	˜	¸	¸	¸	¸
D	-	=	M	]	m	}				ˆ	˜	¸	¸	¸	¸	D	-	=	M	]	m	}				ˆ	˜	¸	¸	¸	¸
E	.	>	N	^	n	~				ˆ	˜	¸	¸	¸	¸	E	.	>	N	^	n	~				ˆ	˜	¸	¸	¸	¸
F	/	?	O	_	o	¸				ˆ	˜	¸	¸	¸	¸	F	/	?	O	_	o	¸				ˆ	˜	¸	¸	¸	¸

The following table shows characters available only in the corresponding character set. The numbers at the top of the table are code values with which characters are to be replaced in the Roman 8 character set. For other characters, see the character set of Roman 8.

SYMBOL SET	23	24	40	5B	5C	5D	5E	60	7B	7C	7D	7E
ISO2 IRV	#	¤	@	[	\	]	^	~	{		}	—
ISO4 UK	£	\$	@	[	\	]	^	~	{		}	—
ISO6 ASCII	#	\$	@	[	\	]	^	~	{		}	—
ISO10 Swedish	#	¤	@	Ä	Ö	Å	^	~	ä	ö	å	—
ISO11 Swedish	#	¤	É	Ä	Ö	Å	Ü	é	ä	ö	å	ü
ISO14 JIS ASCII	#	\$	@	[	¥	]	^	~	{		}	—
ISO15 Italian	£	\$	Š	°	ç	é	^	ù	à	ò	è	ì
ISO16 Portuguese	#	\$	Š	À	Ç	Ö	^	~	ã	ç	õ	°
ISO17 Spanish	£	\$	Š	ı	Ñ	ç	^	~	°	ñ	ç	—
ISO21 German	#	\$	Š	Ä	Ö	Ü	^	~	ä	ö	ü	ß
ISO25 French	£	\$	à	°	ç	Š	^	~	ä	ù	è	—
ISO57 Chinese	#	¥	@	[	\	]	^	~	{		}	—
ISO60 Norwegian1	#	\$	@	Æ	Ø	Å	^	~	æ	ø	å	—
ISO61 Norwegian2	Š	\$	@	Æ	Ø	Å	^	~	æ	ø	å	
ISO69 French	£	\$	à	°	ç	Š	^	~	μ	é	ù	è
ISO84 Portuguese	#	\$	ˆ	À	Ç	Ö	^	~	ã	ç	õ	—
ISO85 Spanish	#	\$	ˆ	ı	Ñ	Ç	ç	~	ˆ	ñ	ç	—
HP German	£	\$	Š	Ä	Ö	Ü	^	~	ä	ö	ü	ß
HP Spanish	#	\$	@	ı	Ñ	ç	°	~	{	ñ	}	—

□ HP LaserJet IIP, EPSON FX-850, IBM Propritner XL

PC-8													PC-850																						
0	1	2	3	4	5	6	7	8	9	A	B	C	D	E	F	0	1	2	3	4	5	6	7	8	9	A	B	C	D	E	F				
0	▸	0	@	P	`	p	Ç	É	á	í	æ	⌘	⌘	α	≡	0	▸	0	@	P	`	p	Ç	É	á	í	æ	⌘	⌘	ø	Ó	-	±		
1	⊙	◀	!	1	A	Q	a	q	ü	æ	í	æ	⌘	⌘	β	±	1	⊙	◀	!	1	A	Q	a	q	ü	æ	í	æ	⌘	⌘	ø	Ó	B	±
2	⊙	‡	"	2	B	R	b	r	é	æ	ó	ú	⌘	⌘	Γ	≥	2	⊙	‡	"	2	B	R	b	r	é	æ	ó	ú	⌘	⌘	ø	Ó	Ê	±
3	♥		#	3	C	S	c	s	â	ô	ñ	⌘	⌘	π	≤	3	♥		#	3	C	S	c	s	â	ô	ñ	⌘	⌘	ø	Ó	Ë	±		
4	♦		\$	4	D	T	d	t	ä	ö	ñ	⌘	⌘	Σ	⌈	4	♦		\$	4	D	T	d	t	ä	ö	ñ	⌘	⌘	ø	Ó	Ë	±		
5	♣		%	5	E	U	e	u	à	ò	ñ	⌘	⌘	σ	⌋	5	♣		%	5	E	U	e	u	à	ò	ñ	⌘	⌘	ø	Ó	Ë	±		
6	♠	-	&	6	F	V	f	v	â	û	æ	⌘	⌘	μ	‡	6	♠	-	&	6	F	V	f	v	â	û	æ	⌘	⌘	ø	Ó	Ë	±		
7	•	‡	'	7	G	W	g	w	ç	ù	ø	⌘	⌘	τ	≈	7	•	‡	'	7	G	W	g	w	ç	ù	ø	⌘	⌘	ø	Ó	Ë	±		
8	▣	↑	(	8	H	X	h	x	è	ÿ	ø	⌘	⌘	φ	°	8	▣	↑	(	8	H	X	h	x	è	ÿ	ø	⌘	⌘	ø	Ó	Ë	±		
9	○	↓	)	9	I	Y	i	y	ë	ÿ	ø	⌘	⌘	θ	·	9	○	↓	)	9	I	Y	i	y	ë	ÿ	ø	⌘	⌘	ø	Ó	Ë	±		
A	▣	→	*	:	J	Z	j	z	è	ÿ	ø	⌘	⌘	∞	·	A	▣	→	*	:	J	Z	j	z	è	ÿ	ø	⌘	⌘	ø	Ó	Ë	±		
B	♀	←	+	;	K	[	k	{	è	ÿ	ø	⌘	⌘	∞	·	B	♀	←	+	;	K	[	k	{	è	ÿ	ø	⌘	⌘	ø	Ó	Ë	±		
C	♀	↳	,	<	L	\	l		è	ÿ	ø	⌘	⌘	∞	·	C	♀	↳	,	<	L	\	l		è	ÿ	ø	⌘	⌘	ø	Ó	Ë	±		
D	♂	↔	-	=	M	]	m	}	è	ÿ	ø	⌘	⌘	∞	·	D	♂	↔	-	=	M	]	m	}	è	ÿ	ø	⌘	⌘	ø	Ó	Ë	±		
E	♂	▲	.	>	N	^	n	~	è	ÿ	ø	⌘	⌘	∞	·	E	♂	▲	.	>	N	^	n	~	è	ÿ	ø	⌘	⌘	ø	Ó	Ë	±		
F	*	▼	/	? O	_	o	Δ	Å	f	»	⌘	⌘	∞	·	F	*	▼	/	? O	_	o	Δ	Å	f	»	⌘	⌘	ø	Ó	Ë	±				

□ EPSON FX-850

US ASCII

0	1	2	3	4	5	6	7	8	9	A	B	C	D	E	F
0		0	@	P	`	p				0	@	P	`	p	
1		!	1	A	Q	a	q			!	1	A	Q	a	q
2		"	2	B	R	b	r			"	2	B	R	b	r
3		#	3	C	S	c	s			#	3	C	S	c	s
4		\$	4	D	T	d	t			\$	4	D	T	d	t
5		%	5	E	U	e	u			%	5	E	U	e	u
6		&	6	F	V	f	v			&	6	F	V	f	v
7		'	7	G	W	g	w			'	7	G	W	g	w
8		(	8	H	X	h	x			(	8	H	X	h	x
9		)	9	I	Y	i	y			)	9	I	Y	i	y
A		*	:	J	Z	j	z			*	:	J	Z	j	z
B		+	;	K	[	k	{			+	;	K	[	k	{
C		,	<	L	\	l				,	<	L	\	l	
D		-	=	M	]	m	}			-	=	M	]	m	}
E		.	>	N	^	n	~			.	>	N	^	n	~
F		/	? O	_	o					/	? O	_	o		

USER'S GUIDE

The following table shows characters available only in the corresponding character set. The numbers at the top of the table are code values with which characters are to be replaced in the US ASCII character set. For other characters, see the character set of US ASCII.

SYMBOL SET	23	24	40	5B	5C	5D	5E	60	7B	7C	7D	7E
German	#	\$	§	Ä	Ö	Ü	^	`	ä	ö	ü	ß
UK ASCII I	£	\$	@	[	\	]	^	`	{		}	~
French I	#	\$	à	°	ç	§	^	`	é	ù	è	''
Danish I	#	\$	@	Æ	Ø	Å	^	`	æ	ø	å	-
Italy	#	\$	@	°	\	é	^	`	à	ò	è	ì
Spanish	¤	\$	@	¡	Ñ	¿	^	`	''	ñ	}	~
Swedish	#	¤	É	Ä	Ö	Å	Ü	é	ä	ö	å	ü
Japanese	#	\$	@	[	¥	]	^	`	{		}	~
Norwegian	#	¤	É	Æ	Ø	Å	Ü	é	æ	ø	å	ü
Danish II	#	\$	É	Æ	Ø	Å	Ü	é	æ	ø	å	ü
UK ASCII II	#	£	@	[	\	]	^	`	{		}	~
French II	#	â	à	î	ç	ê	û	ô	é	ú	è	ï
Dutch	#	\$	@	[	]	f	^	`	é	ij	è	''
South African	#	ê	É	Ê	Ö	è	Ü	é	ë	ö	ô	ü



## Trademarks

The Brother logo is a registered trademark of Brother Industries, Ltd.

TrueType is a trademark of Apple Computer, Inc.

Epson is a registered trademark and FX-80 and FX-850 are trademarks of Seiko Epson Corporation.

Hewlett Packard is a registered trademark and HP LaserJet II and IIP are trademarks of Hewlett-Packard Company.

IBM, IBM PC, and Proprinter are registered trademarks of International Business Machines Corporation.

Microsoft and MS-DOS are registered trademarks of Microsoft Corporation. Windows is a registered trademark of Microsoft Corporation in the U.S. and other countries.

Adobe, Photoshop and Illustrator are trademarks of Adobe Systems, Incorporated.

PaperPort is a trademark of Visioneer Inc.

Unimessage is a trademark of WordCraft.

All other brand and product names mentioned in this User's Guide are registered trademarks of their respective companies.

## Compilation and Publication Notice

Under the supervision of Brother Industries Ltd., this manual has been compiled and published, covering the latest product's descriptions and specifications.

The contents of this manual and the specifications of this product are subject to change without notice.

Brother reserves the right to make changes without notice in the specifications and materials contained herein and shall not be responsible for any damages (including consequential) caused by reliance on the materials presented, including but not limited to typographical and other errors relating to the publication.

©1998 Brother Industries Ltd.

## REGULATIONS

---

**This product is designed for use in a professional environment.**

### **Federal Communications Commission Compliance Notice (For USA Only)**

Responsible Party : Brother International Corporation  
100 Somerset Corporate Boulevard  
Bridgewater, NJ 08807-0911, USA  
TEL: (908) 704-1700

declares, that the products

Product Name: Brother Laser Printer/Scanner/Copier MFC-P200, MC-P2000  
Product Options: ALL

complies with Part 15 of the FCC Rules. Operation is subject to the following two conditions: (1) This device may not cause harmful interference, and (2) this device must accept any interference received, including interference that may cause undesired operation.

This equipment has been tested and found to comply with the limits for a Class B digital device, pursuant to Part 15 of the FCC Rules. These limits are designed to provide reasonable protection against harmful interference in a residential installation. This equipment generates, uses, and can radiate radio frequency energy and, if not installed and used in accordance with the instructions, may cause harmful interference to radio communications. However, there is no guarantee that interference will not occur in a particular installation. If this equipment does cause harmful interference to radio or television reception, which can be determined by turning the equipment off and on, the user is encouraged to try to correct the interference by one or more of the following measures:

- Reorient or relocate the receiving antenna.
- Increase the separation between the equipment and receiver.
- Connect the equipment into an outlet on a circuit different from that to which the receiver is connected.
- Consult the dealer or an experienced radio/TV technician for help.

#### **Important**

A shielded interface cable should be used in order to ensure compliance with the limits for a Class B digital device.

Changes or modifications not expressly approved by Brother Industries, Ltd. could void the user's authority to operate the equipment.

### **Industry Canada Compliance Statement (For Canada Only)**

This Class B digital apparatus complies with Canadian ICES-003.

Cet appareil numérique de la classe B est conforme à la norme NMB-003 du Canada.

### **International Energy Star Compliance Statement**

The purpose of the International Energy Star Program is to promote the development and popularization of energy-efficient office equipments, which includes computers, monitors, printers, facsimile receivers and copy machines world-wide. As an International Energy Star partner, Brother Industries, Ltd. has decided that this product meets the guideline of the program.

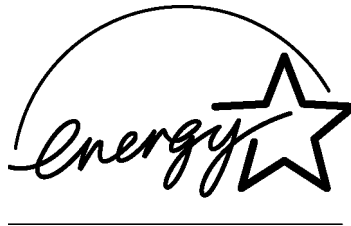

### **Radio Interference (220-240 V Model Only)**

This printer complies with EN55022(CISPR Publication 22)/Class B.

Before this product is used, ensure that you use a double-shielded interface cable with twisted-pair conductors and that it is marked "IEEE 1284 compliant". The cable must not exceed 1.8 metres in length.

### **Laser Safety (For 110–120 V Model Only)**

This printer is certified as a Class I laser product under the U.S. Department of Health and Human Services (DHHS) Radiation Performance Standard according to the Radiation Control for Health and Safety Act of 1968. This means that the printer does not produce hazardous laser radiation.

Since radiation emitted inside the printer is completely confined within protective housings and external covers, the laser beam cannot escape from the machine during any phase of user operation.

### FDA Regulations (For 110-120 V Model Only)

U.S. Food and Drug Administration (FDA) has implemented regulations for laser products manufactured on and after August 2, 1976. Compliance is mandatory for products marketed in the United States. One of the following labels on the back of the printer indicates compliance with the FDA regulations and must be attached to laser products marketed in the United States.

MANUFACTURED:  
Brother Corporation (Asia) Ltd. Brother Buji Nan Ling Factory  
Gold Garden Ind., Nan Ling Village, Buji, Rong Gang, Shenzhen, CHINA  
This product complies with FDA radiation performance standards, 21 CFR Subchapter J

MANUFACTURED:  
BROTHER INDUSTRIES (USA) INC.  
2950 Brother Blvd., Bartlett, TN 38133, U.S.A.  
This product complies with FDA radiation performance standards, 21 CFR Subchapter J

MANUFACTURED:  
BROTHER INDUSTRIES LTD.  
15-1 Naeshiro-cho Mizuho-ku Nagoya, 467 Japan  
This product complies with FDA radiation performance standards, 21 CFR Subchapter J

### Caution

Use of controls, adjustments or performance of procedures other than those specified in this manual may result in hazardous radiation exposure.

### Declaration of Conformity (For Europe)

We, Brother International Europe Ltd.,  
Brother House 1 Tame Street, Guide Bridge, Audenshaw, Manchester M34 5JE, UK.

declare that this product is in conformity with the following normative documents.

Safety:	EN 60950,	EN 60825
EMC:	EN 55022 Class B,	EN 50082-1

following the provisions of the Low Voltage Directive 73/23/EEC and the Electromagnetic Compatibility Directive 89/336/EEC (as amended by 91/263/EEC and 92/31/EEC).

Issued by:  
Brother International Europe Ltd.  
European Technical Services Division

### IEC 825 Specification (For 220–240 V Model Only)

This printer is a Class 1 laser product as defined in IEC 825 specifications. The label shown below is attached in countries where required.



This printer has a Class 3B Laser Diode which emits invisible laser radiation in the Scanner Unit. The Scanner Unit should not be opened under any circumstances.

**Caution**

Use of controls, adjustments or performance of procedures other than those specified in this manual may result in hazardous radiation exposure.

The following caution label is attached near the scanner unit.



## USER'S GUIDE

### **For Finland and Sweden LUOKAN 1 LASERLAITE KLASS 1 LASER APPARAT**

Varoitus! Laitteen käyttäminen muulla kuin tässä käyttöohjeessa mainitulla tavalla saattaa altistaa käyttäjän turvallisuusluokan 1 ylittävälle näkymättömälle lasersäteilylle.

Varning – Om apparaten används på annat sätt än i denna Bruksanvisning specificerats, kan användaren utsättas för osynlig laserstrålning, som överskrider gränsen för laserklass 1.

### **IMPORTANT - For Your Safety**

To ensure safe operation the three-pin electrical plug supplied must be inserted only into a standard three-pin power point which is properly grounded through normal household wiring.

Extension cords used with the equipment must be three-pin plug type and correctly wired to provide proper grounding. Incorrectly wired extension cords may cause personal injury and equipment damage.

The fact that the equipment operates satisfactorily does not imply that the power is grounded and that the installation is completely safe. For your safety, if in any doubt about the effective grounding of the power, consult a qualified electrician.

#### **Disconnect device**

This printer must be installed near a power outlet, which is easily accessible. In case of emergencies, you must disconnect the power cord from the power outlet in order to shut off power completely.

### **Geräuschemission / Acoustic Noise Emission (For Germany Only)**

$L_{pa} < 70$  dB (A) DIN 45635-19-01-KL2

**IMPORTANT - Wiring Information (For U.K. only)**

If the power cord supplied with this printer is not suitable for your electrical outlet, remove the plug from the mains cord and fit an appropriate three pin plug. If the replacement plug is intended to take a fuse then fit the same fuse as the original.

If a moulded plug is severed from the power cord then it should be destroyed because a plug with cut wires is dangerous if plugged into a live socket outlet. Do not leave it where a child might find it.

In the event of replacing the plug fuse, fit a fuse approved by ASTA to BS1362 with the same rating as the original fuse.

Always replace the fuse cover. Never use a plug with the cover omitted.

**WARNING - THIS PRINTER MUST BE PROPERLY EARTHED.**

The wires in the mains cord are coloured in accordance with the following code:

Green and yellow:	Ground
Blue:	Neutral
Brown:	Live

The colours of the wiring in the power lead of this printer may not correspond with the markings which identify the terminals in your plug. If you need to fit a different plug, proceed as follows.

Remove a length of the cord outer sheath, taking care not to damage the coloured insulation of the wires inside.

Cut each of the three wires to the appropriate length. If the construction of the plug permits, leave the green and yellow wire longer than the others so that, in the event that the cord is pulled out of the plug, the green and yellow wire will be the last to disconnect.

Remove a short section of the coloured insulation to expose the wires.

The wire which is coloured green and yellow must be connected to the terminal in the plug which is marked with the letter "E" or by the earth symbol or coloured green or green and yellow.

The wire which is coloured blue must be connected to the terminal which is marked with the letter "N" or coloured black or blue.

The wire which is coloured brown must be connected to the terminal which is marked with the letter "L" or coloured red or brown.

The outer sheath of the cord must be secured inside the plug. The coloured wires should not hang out of the plug.

# INDEX

<b>—A—</b>			
Alarm lamp	3-2, 7-1	Factory Reset	3-4
auto-emulation switching	1-4		
<b>—B—</b>			
bitmapped font	A-6		
<b>—C—</b>			
character set	A-7		
control panel	1-2, 3-1		
Copy button	4-1		
cover open	7-2		
cut sheet	2-1		
<b>—D—</b>			
data compression technology	1-5		
Data lamp	3-2		
Document Basis Weight	2-5		
document feeder	1-2		
Document Size	2-5		
document support	1-2		
Document Thickness	2-5		
DOS	7-11		
dpi	1-3		
Drum lamp	3-2		
drum unit	6-7		
life	A-2		
duplex printing	2-9		
<b>—E—</b>			
economy mode	1-5		
emulation	1-4, A-3		
envelope	2-1		
Enlarge/Reduce button	4-2		
Enlarge/Reduce ratio	4-2		
error			
message	7-2		
recoverable	7-1, 7-3		
unrecoverable	7-4, 7-5		
extension wire	1-2		
<b>—F—</b>			
<b>—H—</b>			
hex dump print	3-4		
<b>—I—</b>			
interface	A-3		
error	7-2		
<b>—J—</b>			
jammed paper	7-6		
<b>—L—</b>			
label	2-1		
<b>—M—</b>			
memory	A-3		
full	7-2		
misfeed	7-1		
multi-purpose sheet feeder	1-2, 2-6		
capacity	2-1		
<b>—O—</b>			
operator call	7-1, 7-3		
organizer	2-1		
output tray	1-2, 2-10		
capacity	2-1		
<b>—P—</b>			
paper			
capacity	2-1		
empty	7-1		
jam	7-1, 7-6		
recommended	2-1		
size	2-1		
type	2-1		
paper guide	1-2		



Paper lamp	3-1, 7-1	low	7-1
paper support	1-2	toner cartridge	6-1
parallel interface		life	A-2
pin assignment	A-4	Toner lamp	3-2, 7-1
port	1-2	top cover	1-2
Photo button	4-2	transparency	2-1
Photo lamp	4-2	Twain	1-3
power cord	1-2	Twain compliant scanner driver	5-1
power switch	1-2		
ppm	1-3		
primary corona wire	6-6, 6-14		
print			
media	A-2		
method	A-1		
overrun	7-2		
quality	A-1		
speed	A-1		
printable area	2-4		
Print Config	3-4		
printer driver	A-3		
printer status monitor	1-5		
Print Fonts I	3-4		

—V—

Visioneer PaperPort® LE Software	1-3
----------------------------------	-----

—W—

warm-up	A-1
---------	-----

—R—

Ready lamp	3-1
Remote Printer Console	1-4
resident font	A-6
resolution	1-3, A-1
RPC	1-4

—S—

scannable area	2-5
scanner window	6-13
Scanning	5-1
Scanning from PaperPort application	5-2

service call	7-4
sleep mode	1-5, 3-3

starter sheet	6-10
Stop button	4-1
switch	3-3
symbol set	A-7

—T—

test print mode	3-4
test sample page	3-4
the number of copies	4-3
time-out	3-3
toner	
empty	7-1